

# Table of Contents

<b>1969 Sportster</b> .....	1
<b>Vehicle Identification</b> .....	1
<i>Frame Numbers</i> .....	1
<i>Engine Serial Numbers</i> .....	1
<b>Related Manuals and Documentation</b> .....	2
<i>The Ironhead Multi-Year Parts Catalog Curse</i> .....	4
<i>Search the Sportsterpedia</i> .....	4
<i>Illustrations</i> .....	5
<b>Specifications</b> .....	6
Model Designations .....	6
Dimensions .....	6
Engine .....	7
Capacities .....	8
Clutch .....	8
Drivetrain .....	8
Tires .....	9
<b>Models</b> .....	9
XLH 883 .....	9
XLCH 883 .....	9



# 1969 Sportster

## Model Production Numbers

- XLH 2,700
- XLCH 5,100

## Colors <sup>1)</sup>

- XLH
  - Black with Black Wrinkle tank panels and White Strip.
  - Jet Fire Orange with Black Wrinkle tank panels and White Strip.
  - Birch White with Black Wrinkle tank panels.
  - Options:
    - Sparkling Burgundy with Black Wrinkle tank panels and White Strip.
    - Sparkling Blue with Black Wrinkle tank panels and White Strip.
    - Sparkling Gold with Black Wrinkle tank panels and White Strip.
- XLCH
  - Black with White Strip on tank.
  - Jet Fire Orange with White Strip on tank.
  - Birch White.
  - Options:
    - Sparkling Burgundy with White Strip on tank.
    - Sparkling Blue with White Strip on tank.
    - Sparkling Gold with White Strip on tank.

# Vehicle Identification

## Frame Numbers

There was no frame identification for purpose of ownership on 1957-1969 model Sportsters. However, there were stampings on the different parts of the frame combined with certain features that can be used to date the frame.

[Click Here](#) to view Ironhead Frame Identification in the Sportsterpedia.

## Engine Serial Numbers

The only numbers for the purpose of identification were on the engine case.

- The engine serial number is stamped on the left side of the engine case between the two cylinders. The first 5 or 6 digits represent the year and model <sup>2)</sup>

From 1962-1969, models with 4 digit production (serial) numbers have an even-numbered first digit for even years and odd numbered first digit for odd years.

[Click Here](#) for more specific information on serial numbers and VINs in the Sportsterpedia (including the 1962-1969 Even/Odd Rule).

<b>Engine Serial Number for 1969 Sportsters</b>		
<b>Model Year</b> (first 2 digits)	<b>Model</b> (next few digits) (up to 4)	<b>Sequential Serial#</b> (remaining digits)
69	XLH XLCH	(example) 12345
<b>Example:</b> (69XLH 12345) indicates a 1969 XLH model and is stamped on the Left Engine Case Between the Cylinders <sup>3)</sup>		
Example Serial Number on Engine Reads: 69XLH12345		
69	XLH	12345

## Related Manuals and Documentation

Below are some suggestions for manuals for your ride.

You should have, at minimum, a Factory Service Manual (FSM) and a Factory Parts Catalog for your year model.

### **Factory Service Manuals (FSM);**

The FSM will have the most accurate information, procedures and specs.

Clymer and Haynes make service manuals also for Sportsters but some of the information is in error to the factory FSMs.

And some of the information in the aftermarket manuals is vague in information or procedures but they may have more pictures.

So it is generally said you can get use from both an aftermarket manual and the factory service manuals but get the factory manual first.

### **Parts Catalogs;**

The Parts Catalog has part numbers of course but it also has exploded parts views.

However, IT IS NOT INTENDED TO BE AN ASSEMBLY MANUAL.

And some of the exploded views are confusing or not related to each other on the same pages.

But, all in all, the exploded views do help finding what goes where.

Most of the fasteners listed in the relevant parts catalog individual pages have thread sizes and lengths also in case you need those.

### **Note: ALL 1957-1978 PARTS CATALOGS LIST PARTS FOR PREVIOUS YEARS.**

Below is a simple list of original and "latest edition parts catalogs. The in-between year books may show different part numbers for the same year model bike.

[Click Here](#) to see the Factory Parts Catalog page in the Sportsterpedia for parts catalog uses and a full list of parts catalog numbers from 1957 to present.

(complete list of other parts catalogs and supplement catalogs that pertain to each year model on the

bottom of that page)

Some often acquire several year model parts catalogs and that page will help you decide which ones are right for you.

**Suggested Manuals:**

- **Factory Service Manual (FSM):**
  - **Original:** 1959-1969 Sportster Service Manual (99484-69) loose leaf in binder
  - **Latest Edition:** 1959-1969 Sportster Service Manual (99484-69) in book bound form
- **Factory Parts Catalogs:**
  - **Original:** 1959-1969 Sportster/KH Model Parts Catalog Supplement (99451-69)
    - Issued August, 1968.
    - Updates the 1957-1967 full parts catalog for Sportster / KH Models (99451-67).
    - Lists closest to original parts available for 1969 models.
    - [Click Here](#) to download a PDF from Harley K Model site (2.51mb)<sup>4)</sup>
      - **Use With:** 1957-1967 Sportster/KH Model Parts Catalog (99451-67)  
Issued September, 1966.  
Full parts catalog and lists parts available in 1967 for 1954-1967 models.  
[Click Here](#) to download a PDF from Harley K Model site (49.5mb)<sup>5)</sup>
  - **Latest Update:** 1954-1978 Sportster XLH/XLCH-1000 Parts Catalog (99451-78B)
    - Issued in 1989.
    - Full catalog and lists parts available in 1989 for 1954-1978 models.
    - Includes some parts that were not available in the -78A catalog.
- **Factory Owners Manual:**
  - 1969 Sportster Owners Manual (99466-69)

**Pics of Manual Covers.**

Below are pics of used manual covers (original and latest editions) related to 1969 model Sportsters. See the full list of pertinent catalogs in the link above.

Click on any pic below to enlarge:

1959-1969 FSM (99484-69) <sup>6)</sup> loose leaf outside and inside covers (original)		1959-1969 FSM (99484-69) (latest)	1969 Owners Manual (99466-69)
			
1957-1967 Parts Catalog (99451-67)	1959-1969 Parts Catalog Supplement (99451-69)	1954-1978 Parts Catalog (99451-78B)	



## The Ironhead Multi-Year Parts Catalog Curse

Below is a summary of an article on the Sportsterpedia Parts Catalogs page regarding parts book errors. You can also read the full article from this link: [The Ironhead Multi-Year Parts Catalog Curse](#).

Due to all of the errors and non corrected editions, it's always a good idea to acquire several year parts catalogs surrounding your year model.

Which year catalogs you'll need will depend on many factors but the main Parts Catalog page in the Sportsterpedia will help you decide which ones you need.

[Click Here](#) to see the Parts Catalog page. A full chart of all the parts catalogs made for Ironheads is at the bottom of the page.

- Not all multi-year catalogs will list factory installed parts on your bike.
- You may need several year catalogs to determine factory installed parts for your year model.
- Some parts first appeared or only appeared in Parts Supplements, Service Bulletins or other literature
- Later catalogs may show parts for older models that were never factory installed on them.
- Some catalogs have missing parts and/or missing models in some parts listings.
- Some illustrations do not have a part number listed.
- Drawings may or may not look like your part number.
- Some exploded parts diagrams show the assembly in the wrong order or missing pieces.
- There may be misleading information about parts that fit your year model.
- Fastener lengths and thread pitch may change depending on catalog used.
- The MoCo knew about and tried to correct at least some of the parts catalog mistakes.

## Search the Sportsterpedia

See the Navigation menu on the upper left of this page.

From there you can go to the main Ironhead section menu, the Reference section for general and in-depth procedures, and the Misc Resources for documentation.

## Illustrations

The following illustrations are displayed for historic and period specific parts identification only. Refer to the original OEM documents for additional information. <sup>7)</sup>

Click on any illustration below to enlarge.

1969 Sportster XLCH

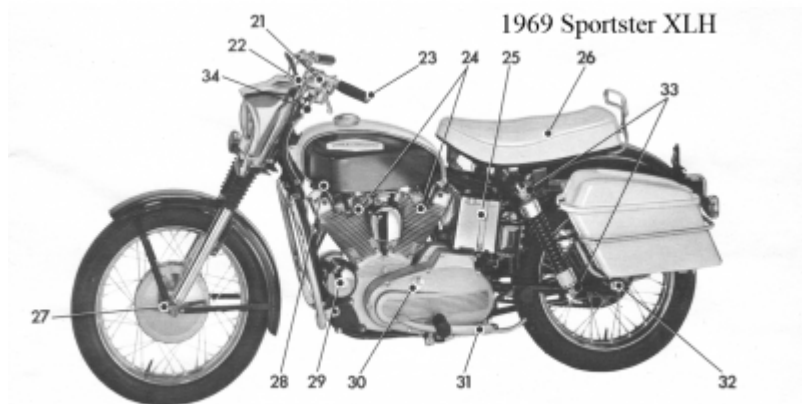
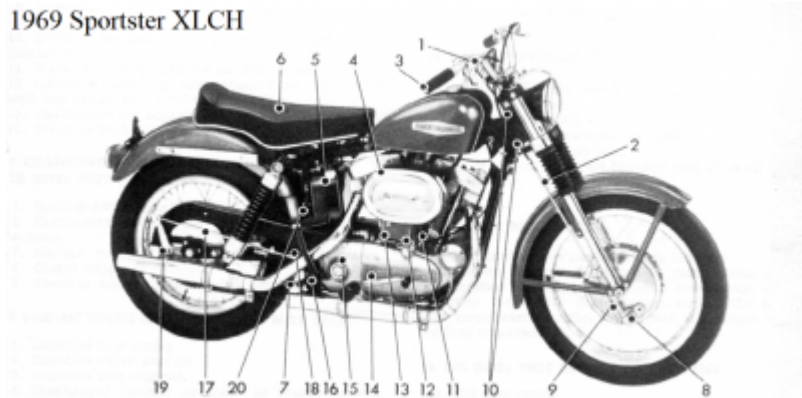

General frame dimension drawings:

- (L) for 1957-1966 XLH / 1957-1969 XLCH “short frames”  
It's a 1966 drawing of a 1966 XLCH frame.
- (R) This is the 'correct' drawing for late 1973-1978 “long frames”. Dims are also good for 1967-1969 XLH and 1970-E1973 (all models). <sup>8)</sup>

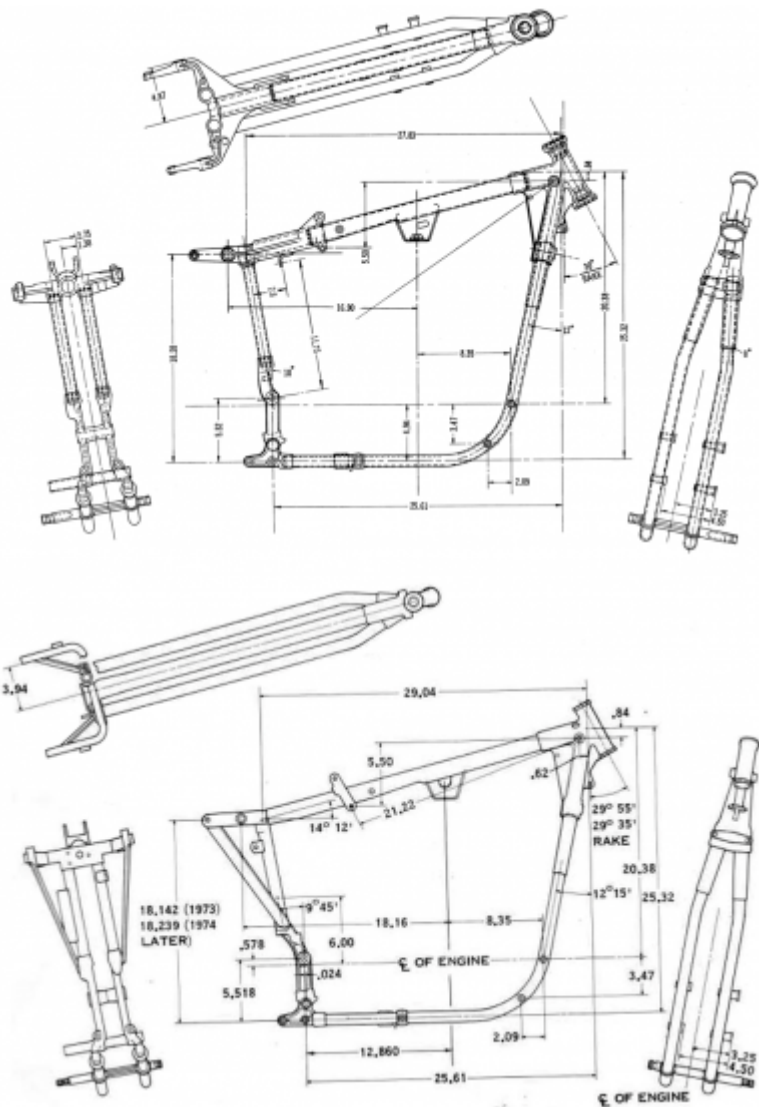

## Specifications

[Click Here](#) for the main technical menu in the Sportsterpedia.

Also see the "Misc Resources" section on the bottom of that page for technical docs and information.

### Model Designations

- XLH, XLCH

### Dimensions

- Wheelbase: <sup>9)</sup>
  - XLH, 56.5 in / 143.51 cm



- XLCH, 58-1/2 in / 148.59 cm
- Overall Length:
  - XLH, 89 in / 226.06 cm
  - XLCH, 83.25 in / 211.45 cm
- Overall Width:
  - XLH, 34 in / 86.36 cm
  - XLCH, 34 in / 86.36 cm
- Overall Height:
  - XLH, 40-1/2 in / 103 cm
  - XLCH, 42 in / 106.7 cm
- Road Clearance:
  - XLH, 5-1/2 in to 6-3/4 in / 13.97 cm to 17.14 cm <sup>10)</sup> (67 and 69 FSMs differ)
  - XLCH, 6-1/2 in to 6-7/8 in / 16.51 cm to 17.46 cm

## Engine

- Engine type: 4 cycle Overhead Valves, 45 degree V2 <sup>11)</sup>
- Hemi-spherical style heads
- Displacement: 53.9 ci / 883 cc (900 cc advertised)
- Compression Ratio: 9:1
- Bore: 3 in / 76.2 mm
- Stroke: 3.8125 in / 96.8 mm
- Horsepower: 55 @ 6,300rpm <sup>12)</sup>
- Taxable Horsepower: 7.2
- Torque: 52 ft-lb @ 3800 RPM
- Weight:
  - XLCH - 188lbs.
  - XLH - 204 lbs.
- Engine serial number stamped on left side case between the two cylinders.  
[Click Here](#) for more information on serial numbers and VINs in the Sportsterpedia.
- 4 Cams
- [Gear driven type oil pump.](#)  
Oil pump pressure (gauge mounted in place of oil pressure switch):
  - Idle, with spark retarded (Min: 3-7 psi)
  - Normal riding conditions: 10-14 psi (6 psi at 20 mph)
- [XLH Ignition](#): Battery Ignition System (circuit breaker/points/timer/distributor)
  - Point Gap: .020"
- [XLCH Ignition](#): Magneto Ignition System
  - Point Gap: .015"
- Dwell: 90° at 1000 RPM
- Ignition Timing
  - Advanced - XLH, XLCH: 45° (11/16") BTDC
  - Retarded - XLH: 15° (5/64") BTDC
- Spark Plugs
  - #4 for everyday use.
  - #5 for hard service.
    - Gap

- XLH: .025"-.030"
- XLCH: .020"
- **Fuel System:** Tillotson HD carburetor.
- **Starter**
  - XLCH: **Kick Start** only.
  - XLH: **Electric Start** only (Prestolite).

## Capacities

- Fuel Capacity: <sup>13)</sup>
  - XLH 4 gal / 15.14 l
  - XLCH 2.2 gal / 8.328 l
- Oil Capacity: 3 qts. / 2.83 l
- Transmission Capacity: 1.5 pints / .71 l

## Clutch

- Multi-Disc dry clutch-pack with alternate steel and fiber friction plates. <sup>14)</sup>

## Drivetrain

- Constant Mesh - right side foot shift <sup>15)</sup>
- Speeds - 4 Forward
- Number of Sprocket Teeth (XLH / XLCH):
  - XLH:
    - Engine: 34
    - Clutch: 59
    - Transmission: 20
    - Rear Wheel: 51
  - XLCH:
    - Engine: 34
    - Clutch: 59
    - Transmission:
      - E1969 - 20
      - Mid 1969 - 19 (beginning on 11-1-1968 with engine serial No. 69XLCH 5921) <sup>16)</sup>
    - Rear Wheel: 51
- Standard Gear Ratios (XLH / XLCH)
  - 1st: 11.16:1
  - 2nd: 8.08:1
  - 3rd: 6.11:1
  - 4th: 4.42:1

## Tires

Tire pressure (based on a rider weighing app. 150 lbs or more).

For each 50 lbs of overload, increase rear tire pressure by 2 lbs, front by 1 lb (but not exceeding manuf max tire pressure). <sup>17)</sup>

- XLH / XLCH:
  - Front: 3.25 / 3.50 x 19 (tire Pressure: 16 psi / 1.10 bar) <sup>18)</sup>
  - Rear: 4.0 x 18 (tire pressure: 20 psi / 1.37 bar) <sup>19)</sup>

## Models

### XLH 883

What is the Current KBB Value? <sup>20)</sup>

### XLCH 883

What is the Current KBB Value? <sup>21)</sup>

---

Back to [Sportster History Index](#)

<sup>1)</sup>

<https://www.harleykmodel.com/technical/colors/index.html>

<sup>2)</sup>

HD Parts Catalog XLH/XLCH-1000 #(99451-78)

<sup>3)</sup>

1953-1963 HD Parts Catalog backside of front cover

<sup>4)</sup>

<https://www.harleykmodel.com/literature/spare-parts-catalogs/documents/99451-69/99451-69.pdf>

<sup>5)</sup>

<https://harleykmodel.com/literature/spare-parts-catalogs/documents/99451-67/99451-67.pdf>

<sup>6)</sup>

pics from a collection by The French Owl of the XLFORUM

<sup>7)</sup>

illustrations from various academic journals

<sup>8)</sup>

Dr Dick of the XLFORUM <http://xlforum.net/forums/showpost.php?p=4370194&postcount=58>

<sup>9)</sup> , <sup>11)</sup> , <sup>12)</sup> , <sup>13)</sup>

Harley-Davidson 1957 - 1969 Service Manual

<sup>10)</sup>

## HD 1969 Sportster Service Manual

<sup>14)</sup>

1957-1969 HD FSM pg 4A-3

<sup>15)</sup>

1957-1969 HD FSM pg 1A-3

<sup>16)</sup>

TSB #582 dated 12-17-1968

<sup>17)</sup>

1959-1964 HD FSM pg 1A-3

<sup>18)</sup> <sup>19)</sup>

HD TSB #516A dated October 15, 1966

<sup>20)</sup>

<http://www.kbb.com/motorcycles/harley-davidson/xlh-sportster/1969-harley-davidson-xlh-sportster/trade-in/>

<sup>21)</sup>

<http://www.kbb.com/motorcycles/harley-davidson/xlch-sportster/1969-harley-davidson-xlch-sportster/trade-in/>

From:

<http://sportsterpedia.com/> - **Sportsterpedia**

Permanent link:

[http://sportsterpedia.com/doku.php/sportster\\_history:1969\\_sportster](http://sportsterpedia.com/doku.php/sportster_history:1969_sportster)

Last update: **2021/11/15 04:38**

