

SERVICE BULLETIN



M-1011

March 26, 1991

CRANKCASE INFORMATION FOR 1340 CC. MODELS

Purpose

The purpose of this Bulletin is to inform you of a test procedure that will locate leaks between the left crankcase half and the primary chaincase, to provide methods for repairing any leaks that are discovered and to inform you of several important crankcase reassembly procedures.

Symptoms

Oil transfer may occur in one or both directions; i.e., engine oil may transfer to the primary chaincase or primary chaincase lubricant may transfer to the crankcase. Symptoms are as follows:

- A. **Engine oil to primary:** An overfilled primary chaincase indicates that engine oil is being transferred from the crankcase to the primary chaincase.
- B. **Primary Chaincase lubricant to crankcase:** An overfilled oil tank along with a low lubricant level in the primary chaincase are symptoms of primary chaincase lubricant transferring to the crankcase.

NOTE

An overfilled oil tank will also typically cause or aggravate "oil carry-over" at air cleaner.

Tools And Material Required

- 1. An air supply regulated to 10-15 pounds per square in. (psi)
- 2. An assortment of compensating sprocket spacers
- 3. A one liter bottle with sprayer of S100® cleaner, H-D Part No. 499760-85T
- 4. A 3/8 in. hose nipple, H-D Part No. 63792-77
- 5. Loctite® 242
- 6. Several feet of 3/8 in I.D. hose

- 7. A propane gas torch
- 8. A tube of 3M® #800 sealant, H-D Part No. 99650-81

Test Procedure

- 1. Refer to the Service Manual that covers the motorcycle being tested and remove the primary cover.
- 2. Remove the compensating sprocket, primary chain, clutch and chain adjuster as an assembly.
- 3. Remove the alternator rotor and stator. **Install stator connector screws (item 3, Figure 4). The stator connector screw holes are "through holes" and would allow pressure to escape during testing.** See Figure 1. Mark or measure and record the factory installed sprocket spacer(s) thickness. The spacer(s) must be installed in their original location to align the primary chain sprockets after the testing is completed.

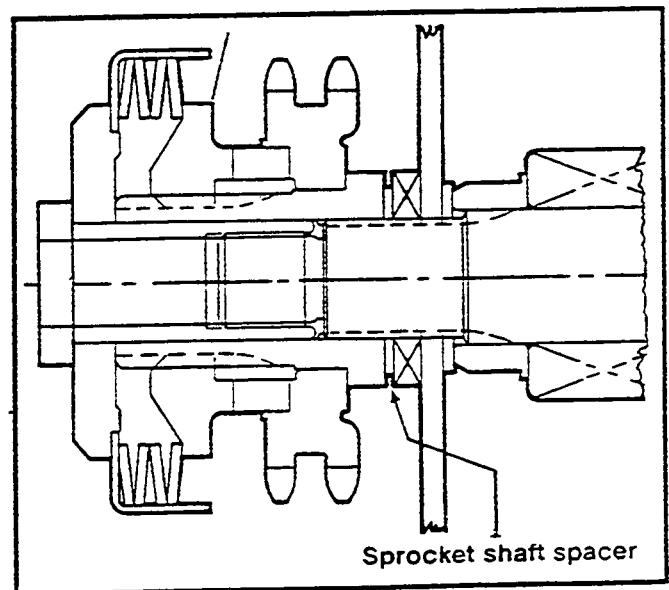

Figure 1. Location Of The Factory Installed Spacer

ROUTING	SERVICE MANAGER	SALES MANAGER	PARTS MANAGER	LEAD TECHNICIAN	TECHNICIAN NO. 1	TECHNICIAN NO. 2	TECHNICIAN NO. 3	TECHNICIAN NO. 4	RETURN THIS TO
INITIAL HERE									

NOTE

On pre-1989 rigid mount engines the inner primary must be removed before the alternator can be removed. Perform test with inner primary removed on pre-1989 rigid mounts.

4. Measure the thickness of the alternator rotor at its bore and select a sprocket shaft spacer of the same approximate thickness. As an alternate, use the thickest sprocket shaft spacer, Part No. 24037-70 in the next step.
5. See Figure 2. Install the rotor spacers (1), the sprocket shaft spacers (2) (selected in step 4) and the spacer(s) installed at the factory) the extension shaft (3), cover assembly (4) and nut (5). Do not install the stator, rotor, compensating sprocket or the primary chain, adjuster or clutch. Tighten the compensating sprocket nut (5) to 80 - 100 ft-lbs of torque.

NOTE

The reason for installing the components and tightening the nut in step 5 is to simulate the preload that is normally present on the sprocket shaft.

6. See Figure 3. Remove the oil tank vent hose (1) at right crankcase and the to-oil-filter hose (2) at the oil pump. Do not disconnect oil feed line (3).
7. Disconnect the crankcase breather hose (4) at the metal tube that is connected to the air cleaner backplate.
8. With a short length of 3/8 I.D. hose (5), connect the oil tank vent fitting to the to-oil-filter fitting on the oil pump. (This connection seals the tank vent.)

WARNING

The application of air pressure, in the next step, may cause rotation of the engine flywheels, so do not touch sprocket shaft with air pressure applied.

9. See Figure 3. Connect the regulated air supply (10-15 psi) hose (6) to the crankcase breather hose (4) using a 3/8 hose nipple (7) (splicer fitting).
10. With the crankcase pressurized, spray the left crankcase with S100® cleaner and watch for bubbles (indication of leakage) at the locations listed in Table 1. If a leak is detected perform the remedy given in Table 1 and then retest to make certain that the detected leak is sealed and no other leaks are present.

NOTE

If no leaks are detected in step 10, perform steps 11 and 12.

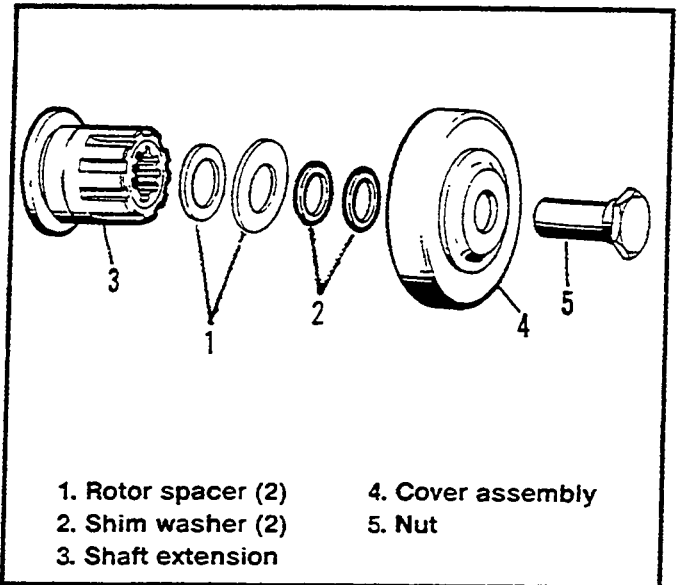

Figure 2. Components To Be Installed For Test

11. See Figure 4. With the propane torch, heat the stator mounting surface for three minutes. (This will simulate engine operating temperature.)

CAUTION

Do not use an acetylene (oxyacetylene) torch, as the excessive heat could damage the crankcase.

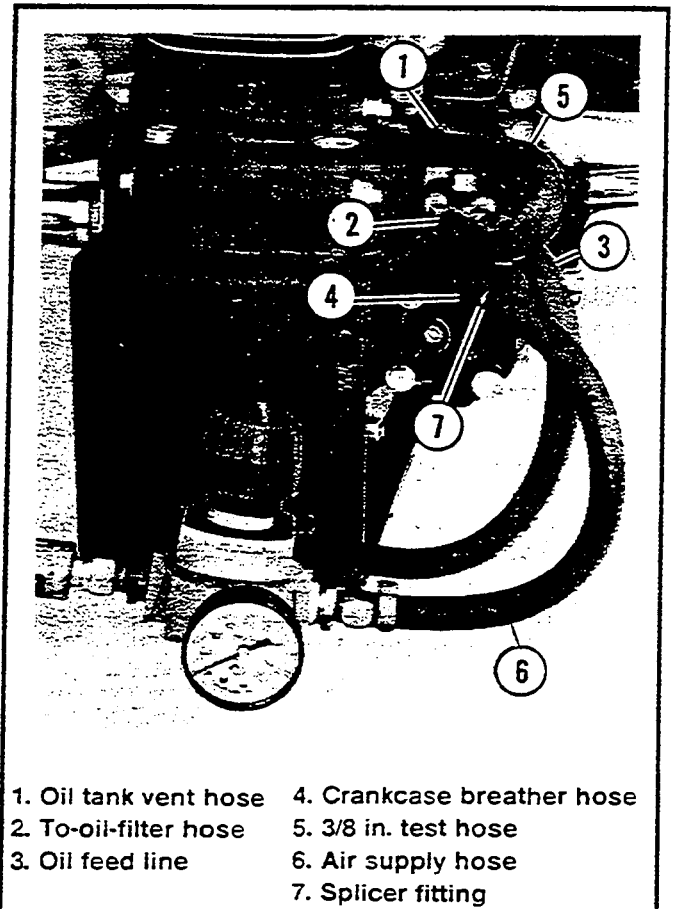

Figure 3. Test Set-up

12. Repeat step 10 to check for leaks after applying heat to left crankcase half.

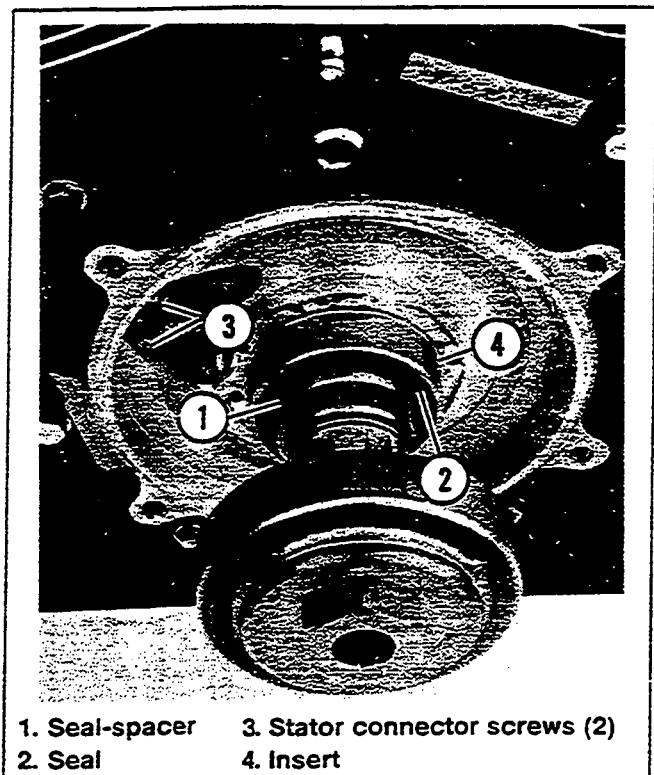

Figure 4. Area To Checked For Leaks

Table 1 Locations To Check For Leaks With Crankcase Pressurized

Test Locations (See Figure 4)	Remedy
<p>1. Seal-spacer (1). Check for leaks at inside diameter (ID) and outside (OD) of seal-spacer.</p>	<p>1.1 If seal-spacer (1) leaks at its ID, remove seal (2) and seal-spacer and check condition of spacer at bearing end. If grooved, install new seal-spacer and new seal. Coat OD of new seal with a very thin application of 3M® 800 and install.</p> <p style="text-align: center;">CAUTION</p> <p>Do not apply 3M® 800 sealant to crankcase or use an excessive amount of 3M® 800 sealant on O.D. of seal. Sealant could be forced into bearing and cause bearing failure. Recheck for leaks.</p> <p>1.2 If leak is at OD of seal-spacer, remove seal (2), Figure 4 and check finish of spacer where lip of seal makes contact. Replace spacer if OD is rough or grooved at seal mating surface. Install new seal (2) after applying sealant as specified in 1.1 above.</p>
<p>2. ID and OD of seal (2).</p>	<p>2.1 If seal (2) leaks at its ID, remove seal and check spacer finish as covered in 1.2 above. Install new seal (2) after applying sealant as specified in 1.1 above and a new seal-spacer if necessary.</p> <p>2.2 If seal leaks at its OD, remove seal and discard. Install new seal (2) after applying sealant as specified in 1.1 above.</p>
<p>3. Stator connector screws (3).</p>	<p>3.1 Seal leaks at fasteners by applying Loctite® 242 (blue) to the threads after stator has been installed.</p>
<p>4. Cast-in insert (4). Check carefully for leaks at the OD of the insert.</p> <p style="text-align: center;"><i>NOTE</i></p> <p><i>Late 1990 and later crankcases do not contain insert.</i></p>	<p>4. If leaks are present at the mating surface between steel insert and crankcase contact the Harley-Davidson Service Department. If crankcase must be replaced, tighten crankcase and cylinder/cylinder head fasteners following instructions on next page.</p>

CRANKCASE TORQUE SEQUENCE:

CAUTION

Follow torque procedure when assembling crankcases. If this torque procedure is not followed, the longevity of the crankcases may be compromised.

1. See Figure 5. Tighten crankcase fasteners to 10 ft-lbs torque in the sequence shown.

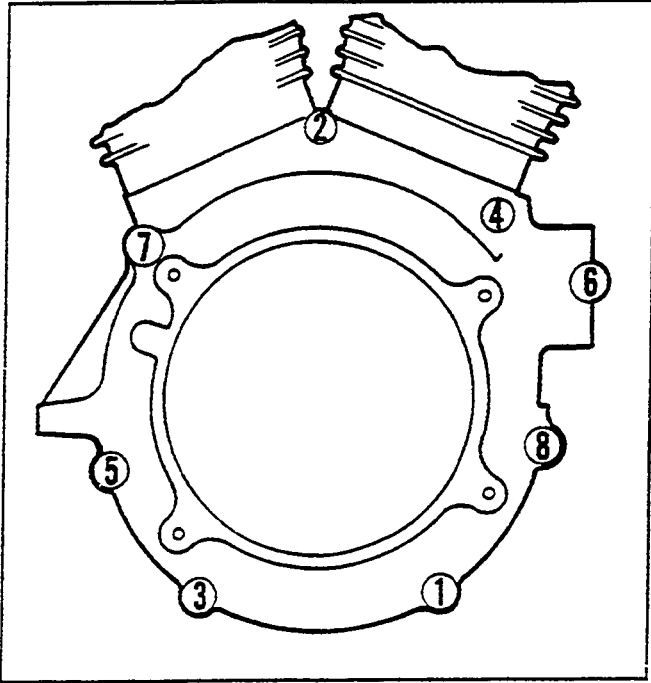

Figure 5. Crankcase Torque Sequence

2. See Figure 6. Install cylinders and heads. The procedure for tightening the head bolts is extremely critical: not only to prevent gasket leaks, but to prevent failure of the studs and distortion of the heads and cylinders.

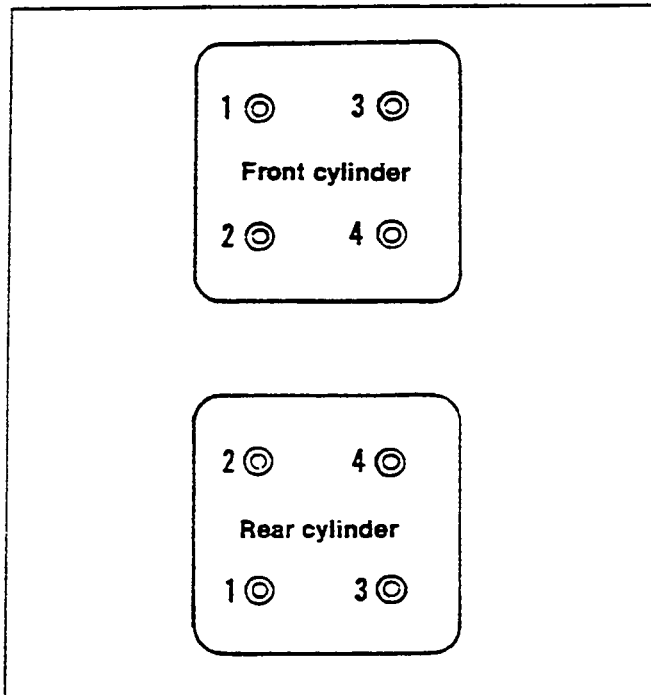

Figure 6. Cylinder Heads Torque Sequence

CYLINDER HEADS TORQUE SEQUENCE:

CAUTION

Be sure you thoroughly clean and lubricate the head bolts before tightening to the correct torque. Friction because of dirt or grime will cause the torque wrench readings to be incorrect. Clean and lubricate the threads with engine oil and screw the bolts onto the crankcase studs to be sure there is no friction.

- a. See Figure 6. With a torque wrench, start at the head screw numbered "1" and tighten to 7 ft-lbs torque. Then tighten "2", "3" and "4", in order, to 7 - 9 ft-lbs torque.
 - b. Again, starting at the head screw numbered "1" and ending with "4" sequentially, tighten each screw to 12 - 14 ft-lbs torque.
 - c. See Figure 7. Mark a line on the cylinder head and a corresponding line on the head of the cylinder head screw as shown in View A. Following the same sequence 1, 2, 3, then 4, turn each head screw, one at a time one quarter turn (90°) using the marks as a guide. When marks are all positioned, as in View B, the procedure is completed.
3. See Figure 5. Tighten crankcase fasteners to 15 - 17 ft-lbs torque in the sequence shown.

NOTE

See Figure 5. On some models, the horn bracket is secured by stud (2) on the left crankcase half. To install the horn bracket loosen the left nut on stud (2), install the bracket and tighten stud (2) to 15 - 17 ft-lbs torque.

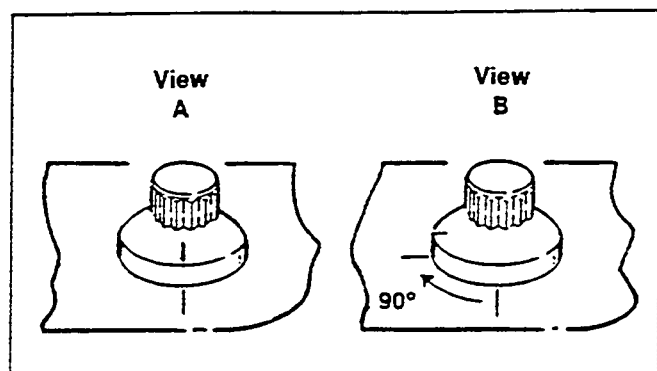

Figure 7. Tighten Head Bolts