

# SERVICE BULLETIN



B-075

Safety Recall Code 0834

June 23, 2008

## 2008 1125R TRANSMISSION JET RECALL

### Purpose

Buell Motorcycle Company has determined that a condition affecting motor vehicle safety exists on certain 2008 1125R motorcycles. These vehicles can experience 5th gear galling on the clutch shaft due to lack of lubrication. This condition can allow the gear to seize to the shaft, resulting in rear wheel lock-up. This could result in an accident, which could cause injury or death to the rider.

In the interest of motor vehicle safety and customer satisfaction, Buell Motorcycle Company has elected to initiate a voluntary recall (Campaign 0834) to install an oil jet in the clutch shaft. As required by law, you may sell but **not deliver** any affected motorcycles to your customers until the remedy is completed.

### Motorcycles Affected

This recall applies to 2008 1125R model motorcycles built from the start of production through May 30th, 2008. A VIN list specific to vehicles shipped to your dealership is available via h-dnet.com and is no longer attached to mailed bulletins. This list may be found by following this path:

[h-dnet.com/ServiceToolbox/Safety](http://h-dnet.com/ServiceToolbox/Safety) Campaign and Open VIN lists. Select 0834 campaign to view VIN list.

#### NOTE

*If the vehicle does not appear on your dealer VIN list, refer to Safety and Product Campaign History by VIN link to verify if vehicle is affected.*

### Customer Notification

In accordance with Federal regulations administrated by NHTSA, Buell Motorcycle Company will provide notice to all owners of record of affected products with direction to bring the vehicle in for the recall service.

To protect the safety of our riders, it is our mutual responsibility to ensure the recall service is performed on all affected motorcycles. Therefore, we strongly urge you to perform the recall service even if the motorcycle was not purchased from your dealership.

You are also required to perform the recall service on all affected vehicles in your dealership inventory prior to delivering, renting or leasing those vehicles.

If you are not sure that a safety recall has been completed on a particular motorcycle, check the recall records available on TALON and h-dnet.com.

#### IMPORTANT NOTE

***Because only registered owners will receive notification from us, we request that you contact any owners of vehicles that your records show as unregistered. Advise them of the safety recall and make arrangements for them to come in for recall service. We also require that you provide us with their names, addresses and V.I.N.s as soon as possible to enable us to mail them an owner's letter, as required by the National Traffic and Motor Vehicle Safety Act (as amended).***

#### IMPORTANT NOTE

**In the interest of preserving customer safety and satisfaction, always check for outstanding recalls whenever any motorcycle is brought into your dealership for either maintenance or service.**

ROUTING	SERVICE MANAGER	SALES MANAGER	PARTS MANAGER	LEAD TECHNICIAN	TECHNICIAN NO.1	TECHNICIAN NO. 2	TECHNICIAN NO. 3	WARRANTY PROCESS MANAGER	RETURN THIS TO
INITIAL HERE									

## Kit Ordering Information

Initial wave shipments of recall kits (Part No. 94678Y) will be made the week of June 23, 2008. All kits will be shipped no charge transportation paid via UPS1.

If additional kits are needed, fill in the attached order form and fax it to the Warranty department at 414-343-8346. You must include your dealer number.

### NOTE

*No kit orders will be accepted prior to the termination of the wave shipment date. Orders received prior to the termination of the wave shipments **will be discarded**. Termination notice of wave shipments will be sent.*

Upon completion of the recall on any vehicle, please be certain to follow the instructions listed under "Credit Procedure", and submit your recall claims promptly.

**Table 1. Safety Recall Code 0834  
Kit 94678Y Contents (see Figure 2)**

Quantity	Part No.	DESCRIPTION
1	Q0094.1AM	Oil jet
1	CE0010.1AM	Retaining ring
1	CF0023.1AM	O-ring

## Required Dealer Action

### NOTE

*Placing motorcycle on sidestand will minimize engine oil loss.*

1. Place motorcycle on sidestand.
2. Remove seat.

### WARNING

**To prevent accidental vehicle start-up, which could cause death or serious injury, disconnect negative (-) battery cable before proceeding. (00048a)**

3. Disconnect negative battery cable.
4. Place an oil pan under the engine.
5. See Figure 1. Pry out the plastic plug from the secondary clutch actuator cover.

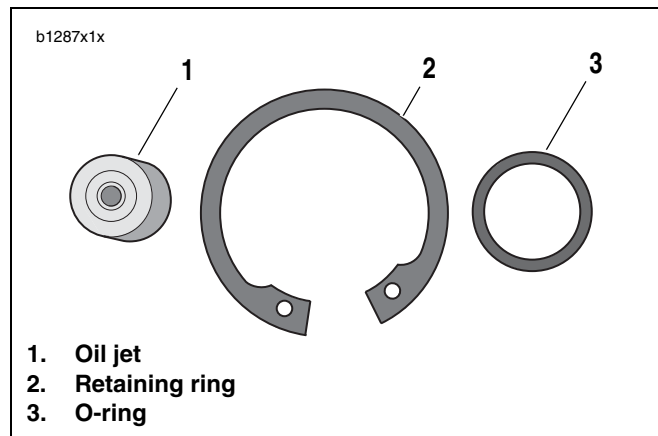
### NOTE

*See Figure 2. The retaining ring (2) holds the actuator piston in place to prevent spilling of clutch fluid.*

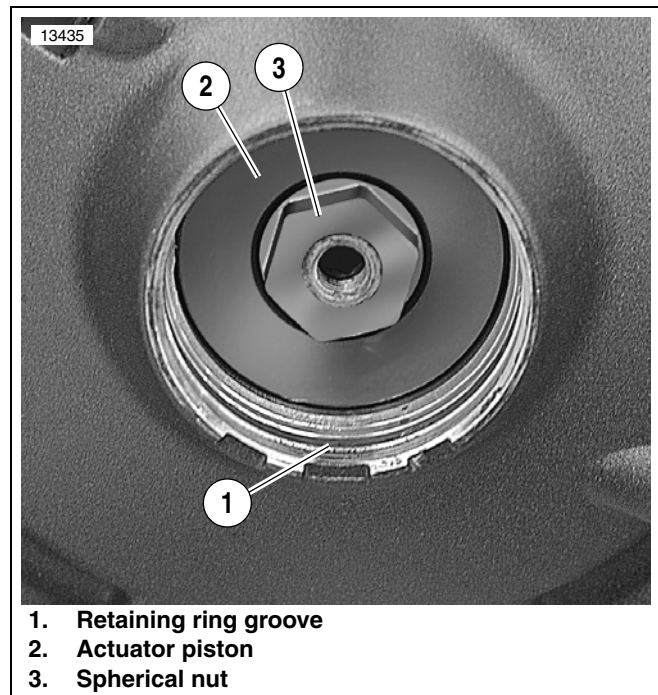
6. See Figure 3. Insert retaining ring into the groove (1) of the secondary clutch actuator cover.



**Figure 1. Secondary Clutch Actuator Cover Plug**



**Figure 2. Oil jet kit**



**Figure 3. Retaining Ring Groove**

- See Figure 4. Use a hex wrench to prevent the clutch release pin from rotating, and use the CLUTCH RELEASE TOOL (Part No. B-49125) to remove the spherical nut. Discard o-ring

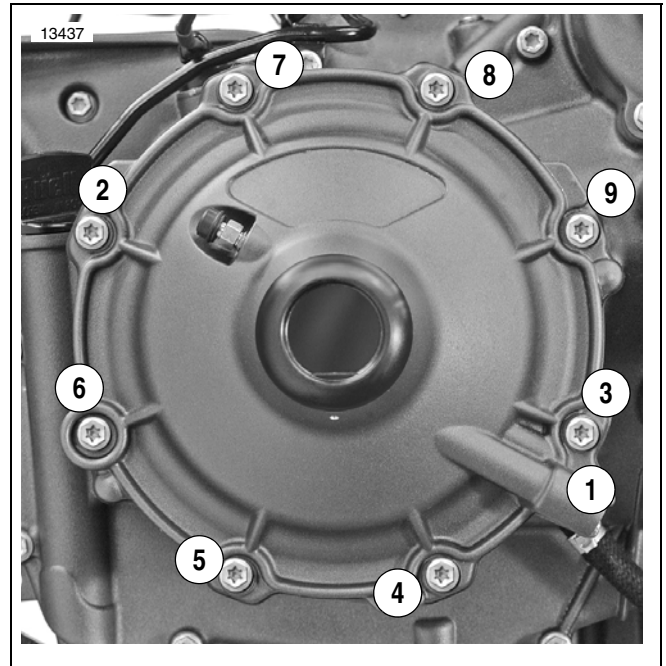
**NOTE**

*In next step, do not remove hydraulic clutch line. Let cover hang from hydraulic line.*

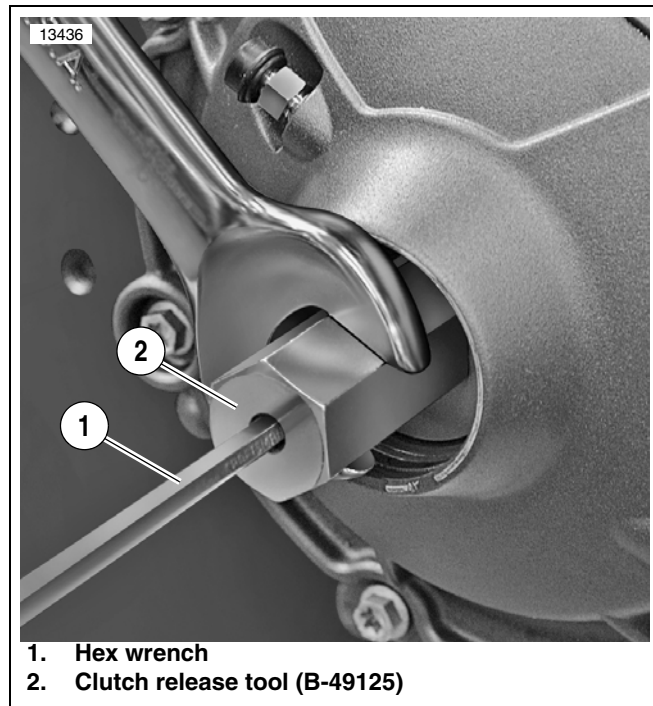
- See Figure 5. Remove the cover fasteners in torque sequence and remove cover.
- See Figure 6. Hold the flat on the clutch release pin (1) and turn off the nut (2).
- Remove the thrust washer (3), the outer disc plate (4) and the diaphragm (5).
- See Figure 7. Remove the inner disc plate (1), inner clutch diaphragm cover (2) and gasket.
- See Figure 8. Slowly loosen (2-3 turns at a time) the spring fasteners (1) in a crisscross pattern.
- Remove the fasteners, stepped washers (2), springs (3) and the pressure plate (4) with attached clutch release pin.

**NOTE**

*If top steel plate sticks to pressure plate during removal, place steel plate back into the clutch hub.*

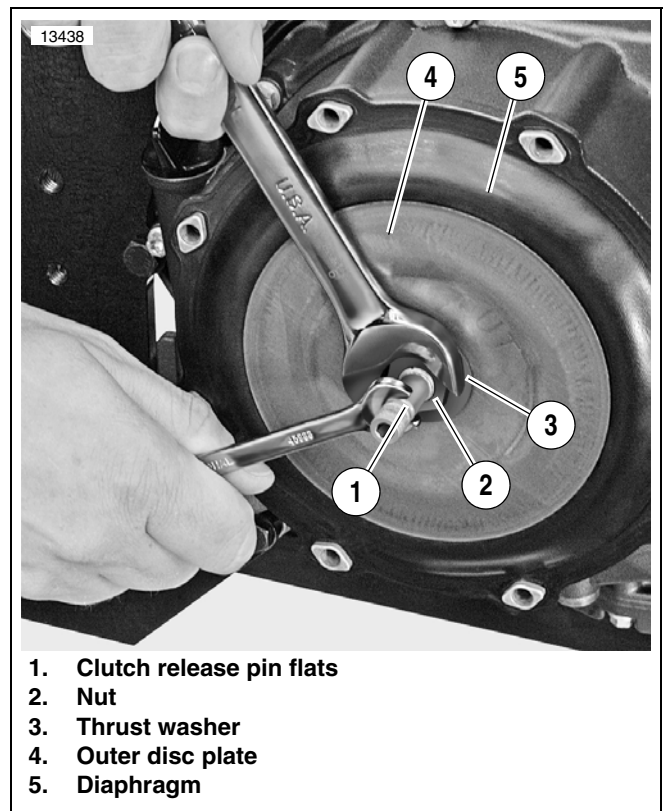


**Figure 5. Secondary Actuator Cover Torque Sequence**



- Hex wrench
- Clutch release tool (B-49125)

**Figure 4. Removing Spherical Nut**



- Clutch release pin flats
- Nut
- Thrust washer
- Outer disc plate
- Diaphragm

**Figure 6. Outer Disc Plate**

14. See Figure 9. Clean clutch shaft bore with contact cleaner.

**NOTE**

See Figure 12. If oil jet has already been installed as a result of efforts by Buell Racing Support, proceed to step 18.

15. See Figure 10. Apply 2-3 drops of LOCTITE 648 (green) or equivalent onto the smaller outside diameter (3) of the oil jet.

**NOTE**

See Figure 10. To install oil jet (2), use a driver (1) that has a larger diameter than the oil jet. The smaller diameter (3) of oil jet faces clutch shaft.

16. See Figure 12. Install oil jet (2) into clutch shaft (1) until oil jet is flush with end of clutch shaft.

17. Clean oil jet with compressed air and make sure nozzle (3) is not blocked.

18. See Figure 13. Fit the stepped washers and fasteners to the springs and install the pressure plate and springs.

19. Install the springs in a cross pattern until the fasteners bottom

20. Tighten the fasteners to 89 **in-lbs** (10 Nm).

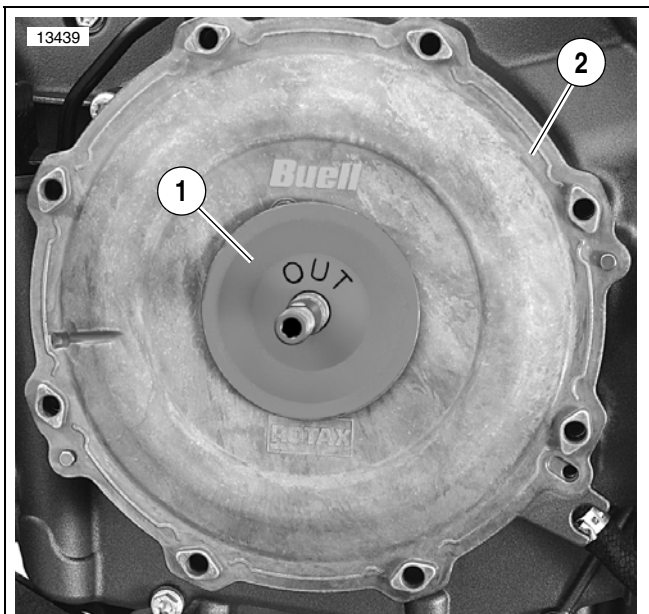
21. See Figure 14. Verify that the two needle pins (1) are in place in the clutch cover.

22. Install the diaphragm cover gasket (2).

23. See Figure 7. Apply LUBRIPLATE No. 105 Motor Assembly Grease to the bore of the inner clutch diaphragm cover (2).

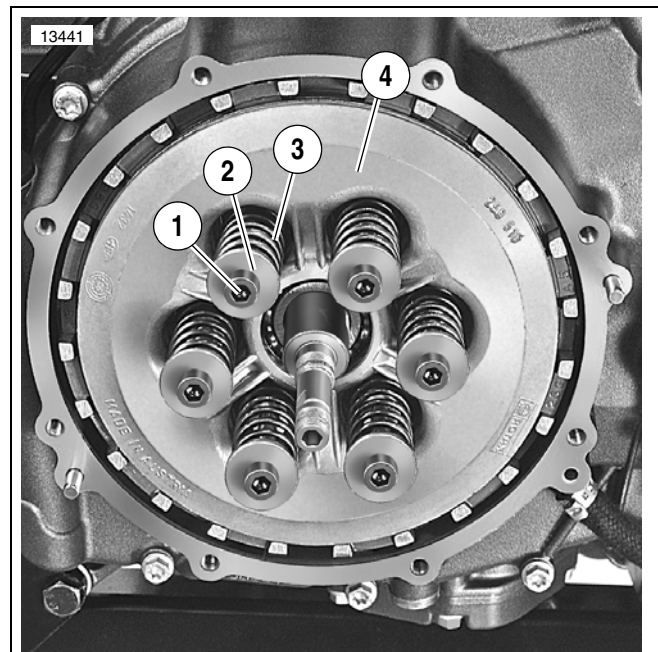
24. Fit the diaphragm cover with the embossed BUELL side out.

25. Install inner disc plate (1) with side stamped "OUT" facing away from engine.



1. Inner disc plate
2. Inner clutch diaphragm cover

Figure 7. Inner Disc Plate



1. Spring fastener
2. Stepped washer
3. Spring
4. Pressure plate

Figure 8. Clutch Springs And Pressure Plate

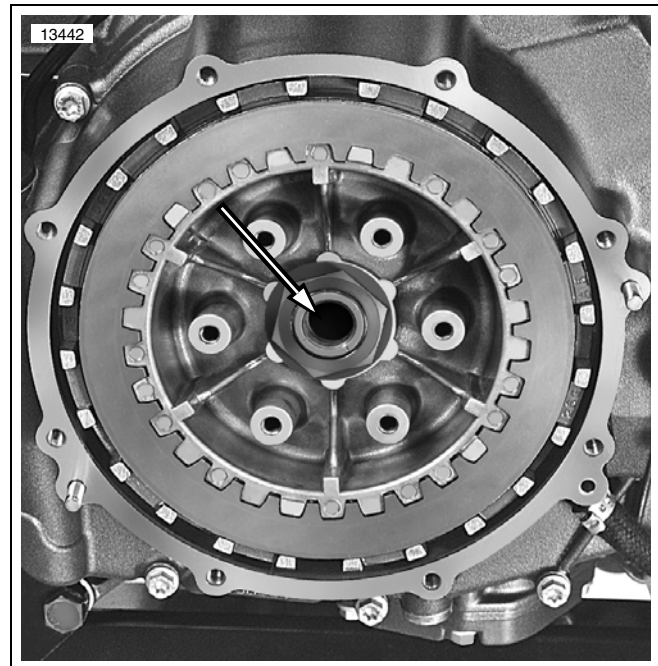
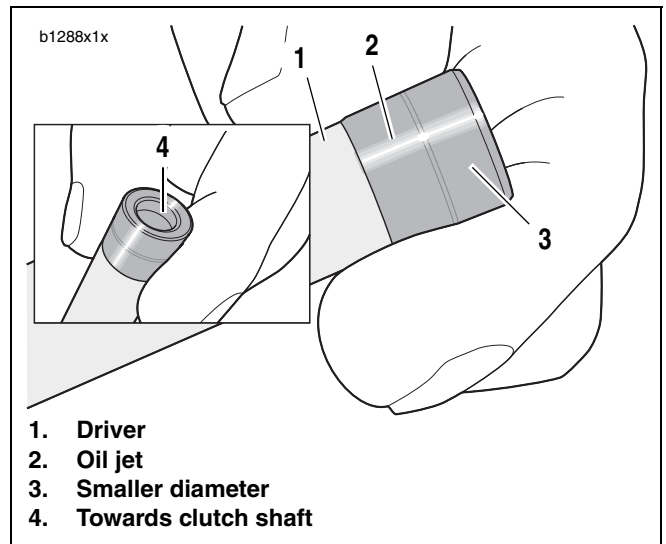


Figure 9. Clutch Shaft Bore

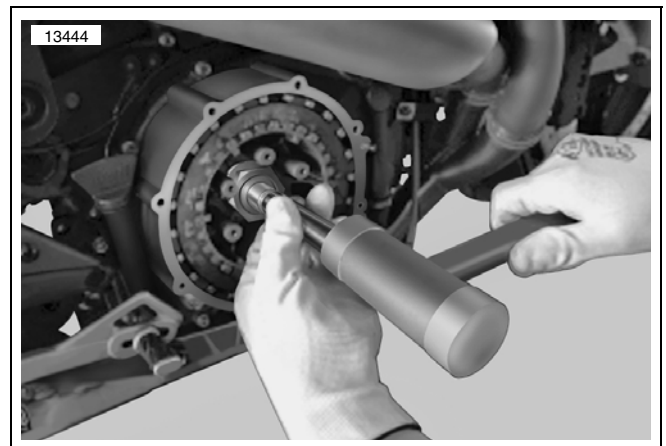


**NOTE**

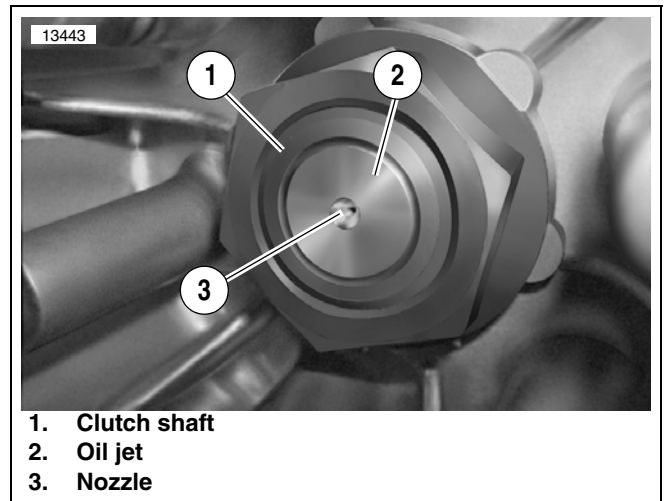
- When fitting the inner cover and the diaphragm to the clutch cover, align the slotted features. The paired fastener holes and the clutch fluid line support fork on the inner cover should be in alignment.
  - Be sure the side of outer disc plate (4) stamped "OUT" is facing away from engine.
26. See Figure 6. Fit the open bowl shape of the diaphragm (5) to the inner disc plate and the cover.
  27. Install the outer disc plate and the thrust washer (3).
  28. Apply LOCTITE 243 (blue) to the threads of the diaphragm clutch release pin nut (2).
  29. Thread on the nut. Holding the flat of the clutch release pin (1), tighten nut to 133 **in-lbs** (15 Nm).
  30. See Figure 5. Install the secondary clutch actuation cover fasteners and tighten in sequence shown to 89 **in-lbs** (10 Nm).



**Figure 10. Oil Jet**



**Figure 11. Oil Jet Installation**



**Figure 12. Installed Oil Jet**

31. Apply clean engine oil to **new** o-ring from recall kit. Install o-ring on spherical nut.
32. Apply LOCTITE 243 (blue) to the threaded hole of the spherical nut.
33. Use a hex wrench to prevent the clutch release pin from rotating, and use the CLUTCH RELEASE TOOL (Part No. B-49125) to tighten the spherical nut to 120 **in-lbs** (14 Nm).
34. See Figure 3. Remove retaining ring from groove (1) in cover.
35. Install plastic plug.
36. Verify engine oil level.
37. Connect negative battery cable.

**CAUTION**

After installing seat, pull upward on seat to be sure it is locked in position. While riding, a loose seat can shift causing loss of control, which could result in death or serious injury. (00070b)

38. Install seat.
39. Start motorcycle and confirm proper clutch function.

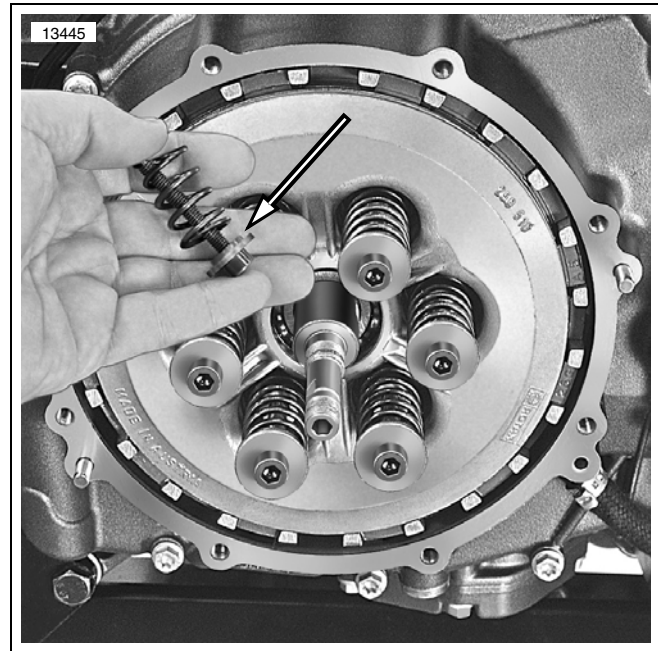


Figure 13. Stepped Washer

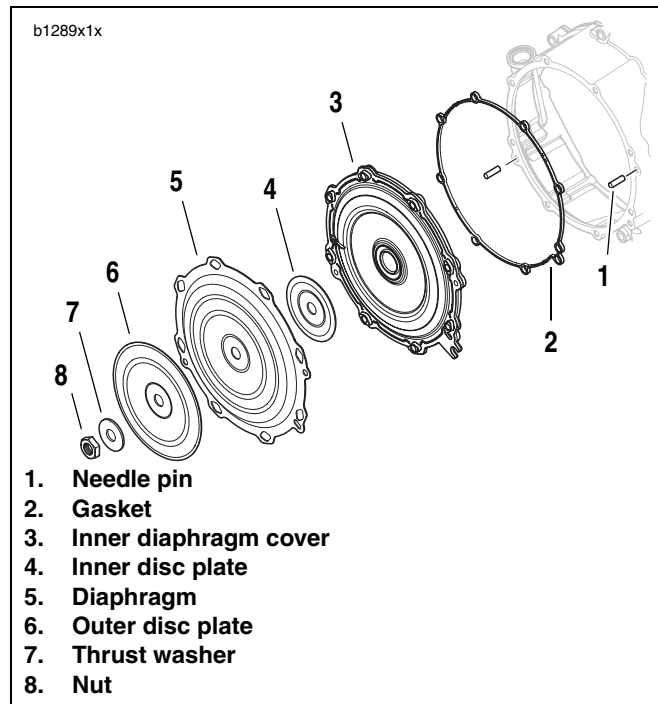


Figure 14. Diaphragm Assembly

## Credit Procedures for all Talon/ h-dnet.com/Lightspeed Warranty Claim Users

For each vehicle serviced, file an electronic recall claim as follows:

**Table 2. Credit Procedures for Talon/  
h-dnet.com/Lightspeed**

ENTRY FIELD	ENTER
Claim Type	SRC
Problem Part	X0041.1AM
Quantity	Leave Blank
* Primary Labor Code	4040
Time	0.6
* Customer Concern Code	0834
Condition Code	9981
Replacement Kit Part No.	94678Y
Quantity	1
*These new codes may need to be downloaded into your system.	

**NOTE**

*Upon receipt of the properly completed recall claim, you will be credited 0.6 hours of labor for performing the procedure, plus appropriate market administrative time. The time also includes the cost of Loctite (purchased locally).*

## Credit Procedures for all other Warranty Claim System Users

For each vehicle serviced, file a claim supplying all necessary information as follows:

Dealer Number

Repair Order Number

Claim Date

Product Campaign (0834)

Fix I.D. (C)

Full seventeen-character V.I.N.

Upon receipt of the properly completed recall claim, you will be credited 0.6 hours of labor for performing the procedure, plus appropriate market administrative time.

**NOTE**

*Each vehicle recall completion must be filed on an individual claim. Please do not submit additional warranty events on these claims.*

**HARLEY-DAVIDSON MOTOR COMPANY**  
**P.O. BOX 594, MILWAUKEE, WI U.S.A 53201**  
**RECALL AND PRODUCT CAMPAIGN ORDER FORM**

**B-075 SAFETY RECALL CODE 0834**

TYPE CODE	ORDER TYPE	VEHICLE IDENTIFICATION NUMBER(S)
RC	RECALL	
PC	PRODUCT CAMPAIGN	

ORDER DATE
DEALER NUMBER

QUANTITY	PART NUMBER	ITEM
	<b>94678Y</b>	Code <b>0834</b>
		<b>NOTE:</b> All orders are subject to approval. You may not receive the total quantity of kits ordered due to parts availability. If this happens, please submit another order for the balance, following all order procedures indicated in the Service Bulletin. Fax orders to the warranty department: 414-343-8346. You must include VIN number (if required) and your dealer number.

**ALL ORDERS SUBJECT TO ACCEPTANCE AT MILWAUKEE, WI USA 53201**

**NOTE:** An order acknowledgement is automatically generated and faxed to your dealership's fax number as listed in GDIS the same day as your order is entered at HDMC. This acknowledgement will provide you with the order status and order number. To retrieve order information based on the Harley-Davidson order number, go to P&A Order Inquiry on h-dnet.com under the Parts and Accessories link, select H-D Order Number, enter the order number and click "Submit". At the bottom of the page, click on "Track Part" to view tracking information for the order.