



# INSTRUCTIONS

-J00037

REV. 8-9-00

Kit Number 25430-89A

## XLH PRIMARY COVER CONVERSION KIT

### General

This kit contains the components necessary to convert a 1994-style XLH primary cover and clutch inspection cover for installation on 1991 - 1993 XLH models.

QTY	DESCRIPTION	PART NUMBER
1	Retaining ring	11046
1	Retaining ring, ramp	11250
1	Screw, clutch adjusting	11752
1	Ramp, outer	25409-94
1	Ramp, outer clutch	25409-94A
1	Cover, chain (polished)	25430-94A
1	Ramp, stationary	25453-87A
1	Square ring	25463-94
1	Clutch cover (polished)	34992-94
1	Spring	36715-94
1	Lock plate	36802-84B
1	Ring, retaining (internal)	37908-90
4	SEMS, buttonhead	943

### ADDITIONAL REQUIRED PARTS (available at your Harley-Davidson Dealer)

QTY	DESCRIPTION	PART NUMBER
1	Primary cover gasket	34955-89A
1	Oil seal, shifter shaft	37101-84
1	O-ring, chain insp. cover	11188
2	O-ring, insp. cover screws	11171
1	O-ring clutch cable	11179

### Installation

#### NOTE

This installation requires using many of the components from the earlier primary cover. Do not discard (unless specified) or damage any components during removal.

### Removing And Stripping Old Primary Cover

#### WARNING

To protect against shock and accidental start-up of vehicle, disconnect the negative battery cable before proceeding. Inadequate safety precautions could result in death or serious injury.

#### WARNING

Always disconnect the negative battery cable first. If the positive cable should contact ground with the positive cable installed, the resulting sparks may cause a battery explosion which could result in death or serious injury.

1. Refer to REMOVAL procedure in the appropriate Service Manual and follow the procedures given to remove the clutch inspection cover and primary cover.
2. See Figure 1. Retain nut (11) for use later.
3. See Figure 3. Retain gear shifter lever, left footrest assembly, and all screws and washers shown in Figure 3.
4. See Figure 1. Refer to CLUTCH RELEASE MECHANISM section in the appropriate Service Manual and perform the DISASSEMBLY procedure.
5. Discard O-ring (3). Retain balls (8) and coupling (10) for use later.
6. Remove the primary chain adjuster, and retain all parts for use later.

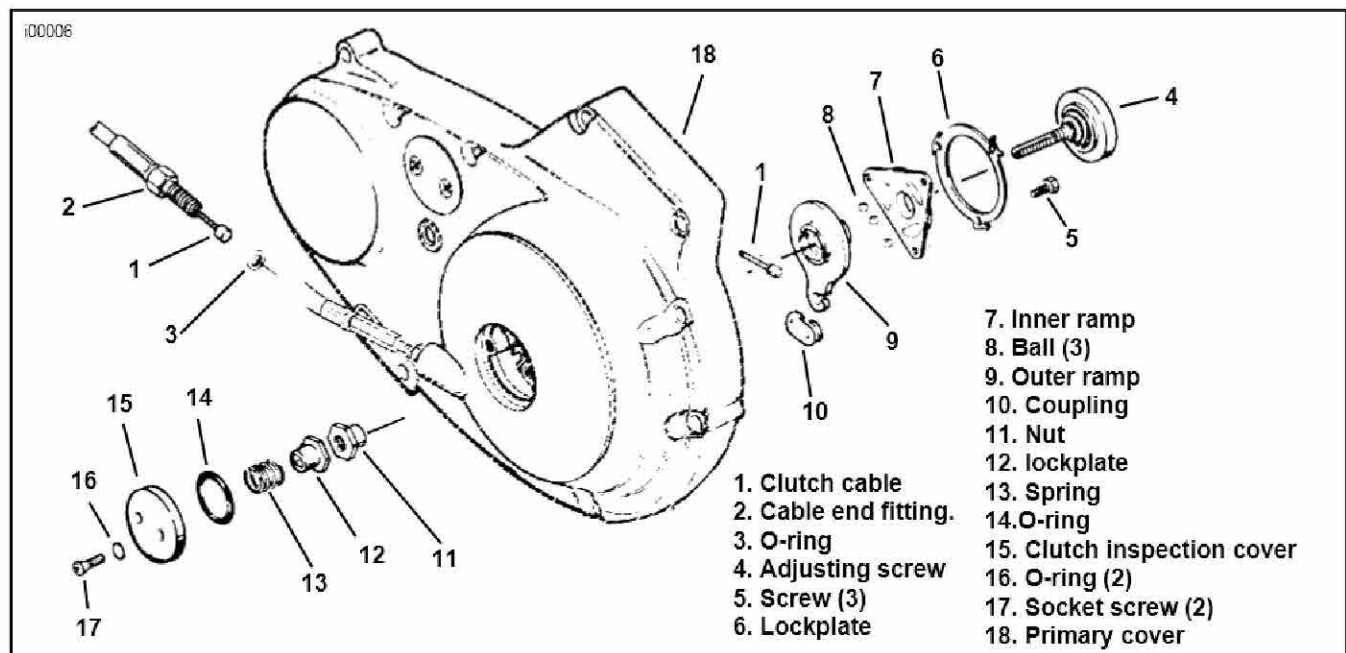

Figure 1. Primary Cover -1991-1993

- See Figure 3. Remove the chain inspection cover screws (5), O-rings (6), inspection cover (7) and O-ring (8). Discard O-rings (Items 6 and 8) but retain screws (5) and inspection cover (7) for later use.

## Removing Clutch Adjusting Screw

### CAUTION

In the next step do not mistakenly attempt to remove the large retaining ring that retains the diaphragm spring. The highly compressed diaphragm spring could fly out and cause personal injury.

- See Figure 4. Remove retaining ring (1) from pressure plate (2). Retaining ring (1) may be discarded.
- Remove release plate (3) containing adjusting screw (4), bearing (5), and retaining ring (6). Retain release plate (3).
- Remove and discard retaining ring (6).
- Support the inner race of bearing (5) and press adjusting screw (4) from bearing. Save bearing (5) but discard clutch adjusting screw (4).

## Installing New Clutch Adjusting Screw

- See Figure 4. Support the inner race of bearing (5), and press new adjusting screw (4) from this kit into bearing (5).
- Install new retaining ring (6) into groove on adjusting screw (4) to retain bearing.
- Insert adjusting screw assembly (3, 4, 5, and 6) into pressure plate (2), and install new retaining ring (1).

## Assembling Parts On New Primary Cover

- Refer to the appropriate Service Manual and install the primary chain adjuster removed from old cover.
- If chain adjuster shoe is excessively worn, install new one

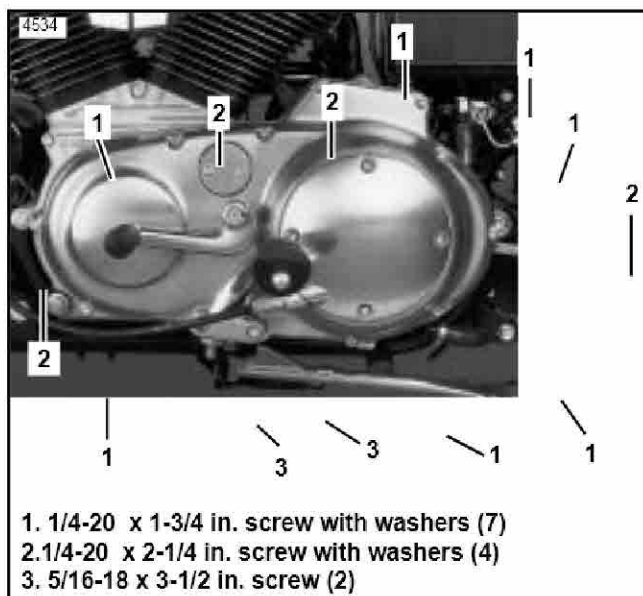

Figure 2. Primary Cover Bolts - 1991-1993 Models

## Installing New Primary Cover

- Remove foreign material from magnetic drain plug. Install plug and tighten to 14-21 ft-lbs (19-28 Nm).
- Install a new primary cover gasket on left crankcase.
- See Figure 2. Install new primary cover onto left crankcase half using saved mounting screws and washers at locations illustrated. Tighten screws to 80-110 in-lbs (9.0-12.4 Nm).
- Install new shifter shaft oil seal, Part No. 37101-84.
- See Figure 5. Apply multi-purpose grease to balls (7) and new ramps (6 and 15). Insert balls in sockets of new outer ramp. Install new inner ramp on hub of outer ramp with tang 180° from hook of outer ramp. Install new retaining ring in groove of outer ramp hub.

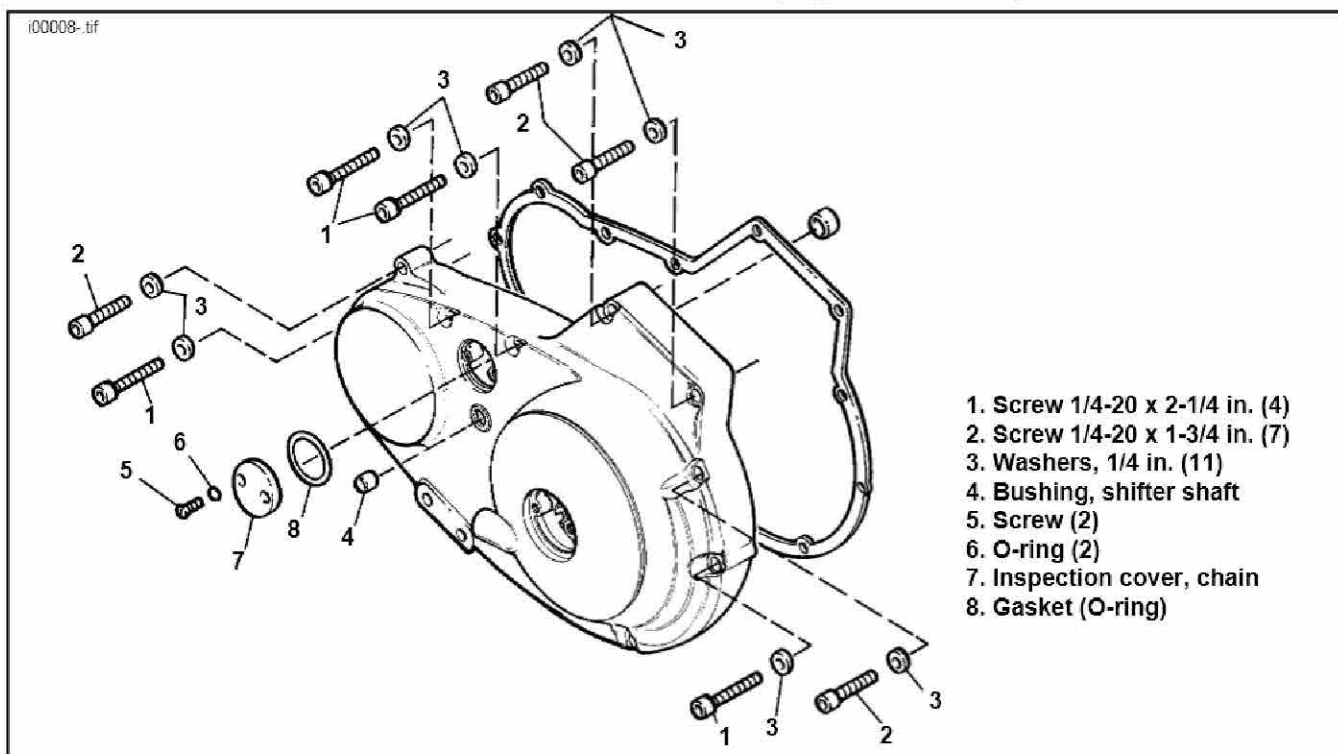
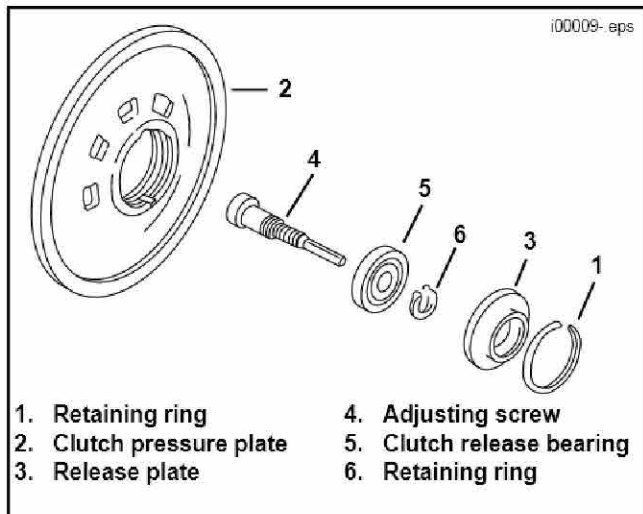

Figure 3. Primary Cover Components



- 1. Retaining ring
- 2. Clutch pressure plate
- 3. Release plate
- 4. Adjusting screw
- 5. Clutch release bearing
- 6. Retaining ring

**Figure 4. Clutch Release Components**

- 6. Install clutch cable fitting (9) with O-ring (8) onto new primary cover (11). Fit coupling (16) over clutch cable end (10) with the rounded side outboard, the ramp connector button inboard. With retaining ring side of ramp assembly facing inward, place hook of ramp (6) around coupling button, and rotate assembly counter-clockwise until tang on inner ramp (15) fits in slot of primary cover.
- 7. See Figure 5. Thread nut (5) on adjusting screw (12) until slot of screw is accessible with a screwdriver. Fit nut hex into recess of outer ramp (6) and turn adjusting screw counter-clockwise.
- 8. Adjust clutch. See CLUTCH RELEASE MECHANISM, ADJUSTMENT in the applicable Service Manual.

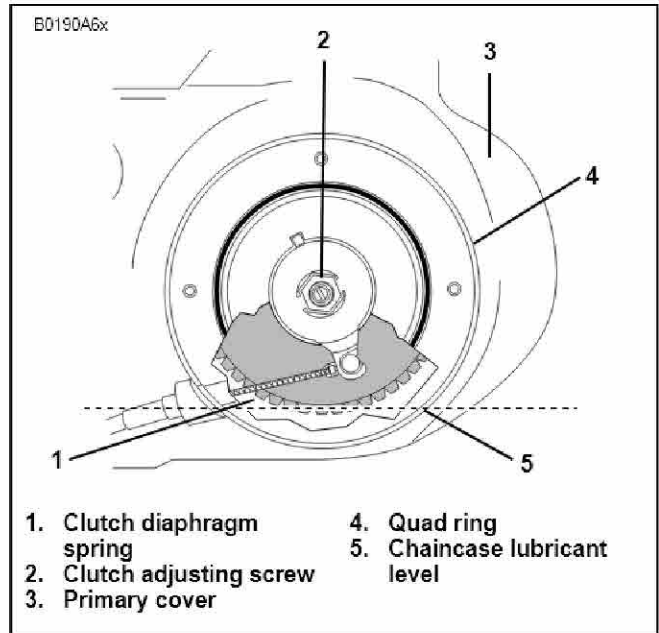

- 1. Clutch diaphragm spring
- 2. Clutch adjusting screw
- 3. Primary cover
- 4. Quad ring
- 5. Chaincase lubricant level

**Figure 6. Chaincase Lubricant Level  
(Clutch release mechanism removed for photo)**

- 9. Adjust primary chain tension. See PRIMARY CHAIN, ADJUSTMENT in the applicable Service Manual.
- 10. See Figure 3. Install original primary chain inspection cover (7) with new gasket (8) using original screws (5) and new O-rings (6).

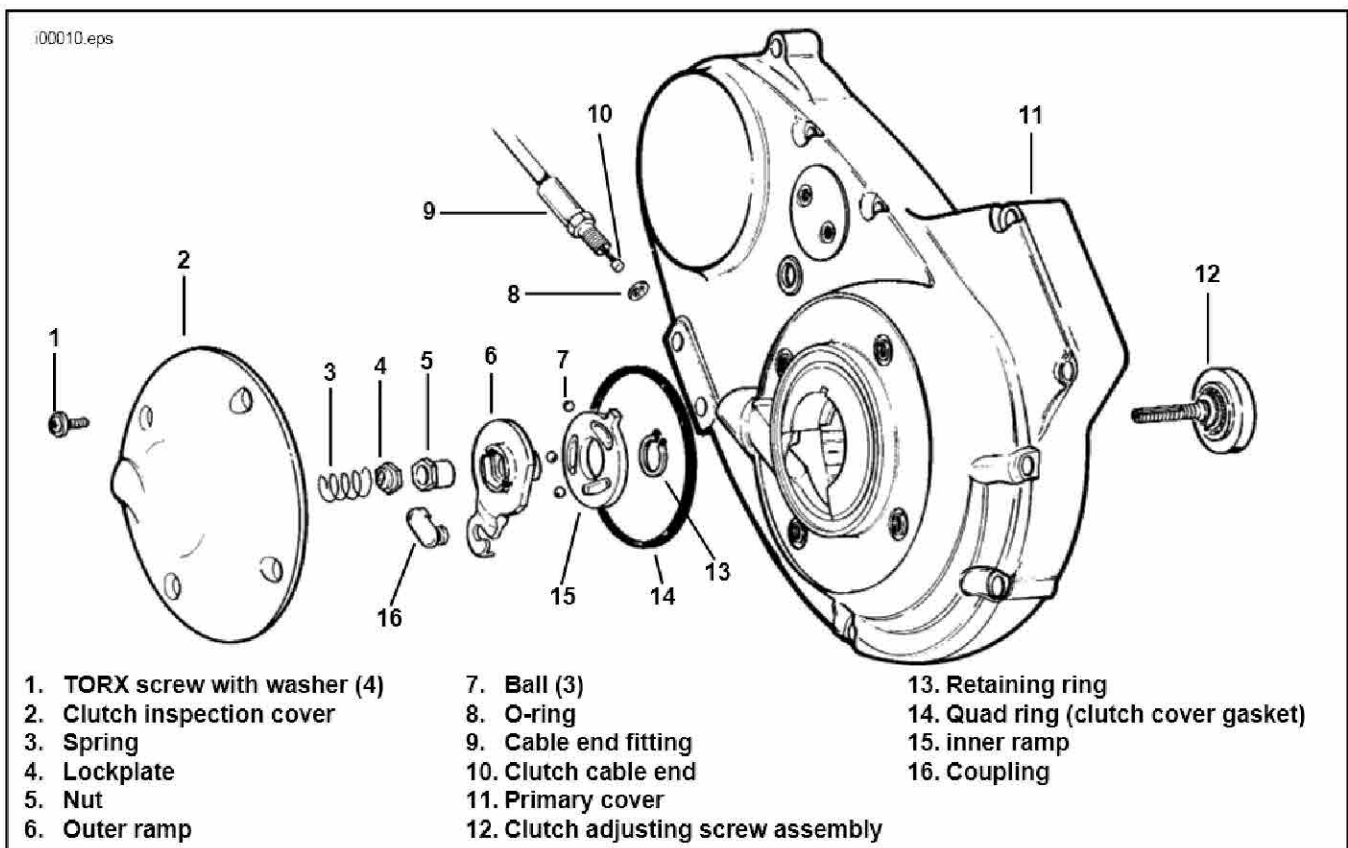

- 1. TORX screw with washer (4)
- 2. Clutch inspection cover
- 3. Spring
- 4. Lockplate
- 5. Nut
- 6. Outer ramp
- 7. Ball (3)
- 8. O-ring
- 9. Cable end fitting
- 10. Clutch cable end
- 11. Primary cover
- 12. Clutch adjusting screw assembly
- 13. Retaining ring
- 14. Quad ring (clutch cover gasket)
- 15. Inner ramp
- 16. Coupling

**Figure 5. Clutch Release Mechanism**

**⚠ CAUTION**

**Do not overfill the primary chaincase with lubricant. Overfilling may cause rough clutch engagement and incomplete disengagement (or clutch drag).**

11. Add 32 fluid ounces (946 ml) of Harley-Davidson Sport-Trans Fluid (Part No. 99896-88=quart size; Part No. 99895-88=gallon size) through clutch inspection cover opening.
12. See Figure 6. Verify that lubricant level (5) is even with bottom of clutch diaphragm spring (1).
13. See Figure 5. Install new lockplate (4) and new spring (3). If hex on lockplate does not align with recess in outer ramp (6), rotate adjusting screw (12) clockwise until alignment occurs.

14. Install new clutch inspection cover (2) on primary cover using new T-27 TORX screws (1) with washers. Tighten screws in a crosswise pattern to 7-9 ft-lbs (9-12 Nm).
15. Install the gear shift lever. Tighten pinch bolt to 80-110 in-lbs (9.0-12.4 Nm).
16. Install left footrest assembly. Tighten footrest mounting bolts to 16-28 ft-lbs (22-38 Nm).

**⚠ WARNING**

**Always connect positive battery cable first. If the positive cable should contact ground with the negative cable installed, the resulting sparks may cause a battery explosion which could result in death or serious injury.**

17. Connect battery cables, positive cable first.