

Table of Contents

- 1957 Sportster** 1
- Vehicle Identification** 1
 - Frame Numbers 1
 - Engine Serial Numbers 1
- Related Manuals and Documentation** 2
 - The Ironhead Multi-Year Parts Catalog Curse* 4
 - Search the Sportsterpedia* 5
 - Illustrations* 5
- Specifications** 6
 - Model Designation 6
 - Dimensions 6
 - Engine 6
 - Capacities 7
 - Clutch 7
 - Drivetrain 7
 - Tires 8

1957 Sportster

The Sportster XL was introduced as “a modern, up-to-date power plant.” 

In 1952, the W models were replaced with the revered 45-cubic inch side-valve K series. The new K-models included an integrated four-cam engine and four-speed transmission design, along with foot shift, swingarm rear suspension, and telescopic front forks to compete with smaller, sportier motorcycles coming mainly from Great Britain. Essentially, the new XL motor was an updated K-model engine with larger displacement, overhead valves and higher compression. - Harley-Davidson Archives Copyright H-D ¹⁾

Model Production Numbers

- XL - Number Produced: 1,983

Colors

- Skyline Blue with Birch White tank panels. ²⁾
- Pepper Red with Black tank panels. ³⁾
- Birch White with Black tank panels. ⁴⁾
- Black with Pepper Red tank panels. ⁵⁾
- Options (no charge): ⁶⁾
 - Fenders to match tank panel when panel is a standard color.
 - Birch White - (indicate either solid or with black panels).
 - Any standard color without tank panels.
- Options (extra charge): ⁷⁾
 - Metallic Midnight Blue with Birch White tank panels.
 - Spring Special: Nugget Gold.

Vehicle Identification

Frame Numbers

There was no frame identification for purpose of ownership on 1957-1969 model Sportsters. However, there were stampings on the different parts of the frame combined with certain features that can be used to date the frame.

[Click Here](#) to view Ironhead Frame Identification in the Sportsterpedia.

Engine Serial Numbers

The only numbers for the purpose of identification were on the engine case.

- For 1957-1961 models, the engine serial number is stamped on the left side of the engine case between the two cylinders.
First 4 or 5 digits are the year and bike model followed by a series of 4 or 5 numbers that established the individual serial number for each bike.

[Click Here](#) for more specific information on serial numbers and VINs in the Sportsterpedia.

Engine Serial Number for 1957 Sportsters		
Model Year (first 2 digits)	Model (next few digits) (up to 4)	Sequential Serial# (remaining digits)
57	XL	(example) 12345
Example: (57XL 12345) indicates a 1957 XL model and is stamped on the Left Engine Case Between the Cylinders ⁸⁾		
Example Serial Number on Engine Reads: 57XL12345		
57	XL	12345

Related Manuals and Documentation

Below are some suggestions for manuals for your ride.

You should have, at minimum, a Factory Service Manual (FSM) and a Factory Parts Catalog for your year model.

Factory Service Manuals (FSM);

The FSM will have the most accurate information, procedures and specs.

Clymer and Haynes make service manuals also for Sportsters but some of the information is in error to the factory FSMs.

And some of the information in the aftermarket manuals is vague in information or procedures but they may have more pictures.

So it is generally said you can get use from both an aftermarket manual and the factory service manuals but get the factory manual first.

[Click Here](#) to view the Factory Service Manual page in the Sportsterpedia.

Parts Catalogs;

The Parts Catalog has part numbers of course but it also has exploded parts views.

However, IT IS NOT INTENDED TO BE AN ASSEMBLY MANUAL.

And some of the exploded views are confusing or not related to each other on the same pages.

But, all in all, the exploded views do help finding what goes where.

Most of the fasteners listed in the relevant parts catalog individual pages have thread sizes and lengths also in case you need those.

Note: ALL 1957-1978 PARTS CATALOGS LIST PARTS FOR PREVIOUS YEARS.

Below is a simple list of original and "latest edition parts catalogs. The in-between year books may show different part numbers for the same year model bike.

[Click Here](#) to see the Factory Parts Catalog page in the Sportsterpedia for parts catalog uses and a full list

of parts catalog numbers from 1957 to present.

(complete list of other parts catalogs and supplement catalogs that pertain to each year model on the bottom of that page)

Some often acquire several year model parts catalogs and that page will help you decide which ones are right for you.

Suggested Manuals:

- **Factory Service Manual (FSM):**
 - **Original:** None. The FSM program didn't begin until the 1959 season. The 1959 FSM states "Except for minor differences, it also applies to 1957-1958 model Sportsters.
 - **Latest Edition:** 1959-1969 Sportster Service Manual (99484-69)
- **Factory Parts Catalogs:**
 - **Original:** 1957 Spare Parts Catalog for all Sportster and K Models Catalog (99451-57)
 - Issued February 15, 1957.
 - Full parts catalog and lists parts available in 1957 for 1952-1957 models.
 - Lists closest to original parts available for 1957 models.
 - [Click Here](#) to download a PDF from Harley K Model site (32.2mb) ⁹⁾
 - **Latest Edition:** 1954-1978 Sportster XLH/XLCH-1000 Parts Catalog (99451-78B)
 - Issued in 1989.
 - Full catalog and lists parts available in 1989 for 1954-1978 models.
 - Includes some parts that were not available in the -78A catalog.
- **Factory Owners Manual:**
 - 1957 Sportster Rider Handbook (99466-57)

Pics of Manual Covers.

Below are pics of used manual covers (original and latest editions) related to 1957 model Sportsters.

See the full list of pertinent catalogs in the link above.

Click on any pic below to enlarge:

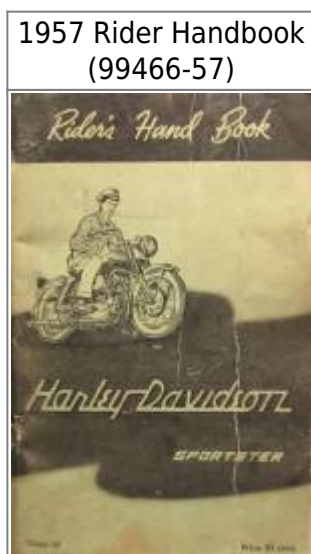

1959 FSM (99484-59) ¹⁰⁾ loose leaf inside and outside covers (original)	1959-1969 FSM (99484-69) book bound cover (latest)	1957-1969 FSM (no part#) (few page dates of Feb. 1970)
---	---	---

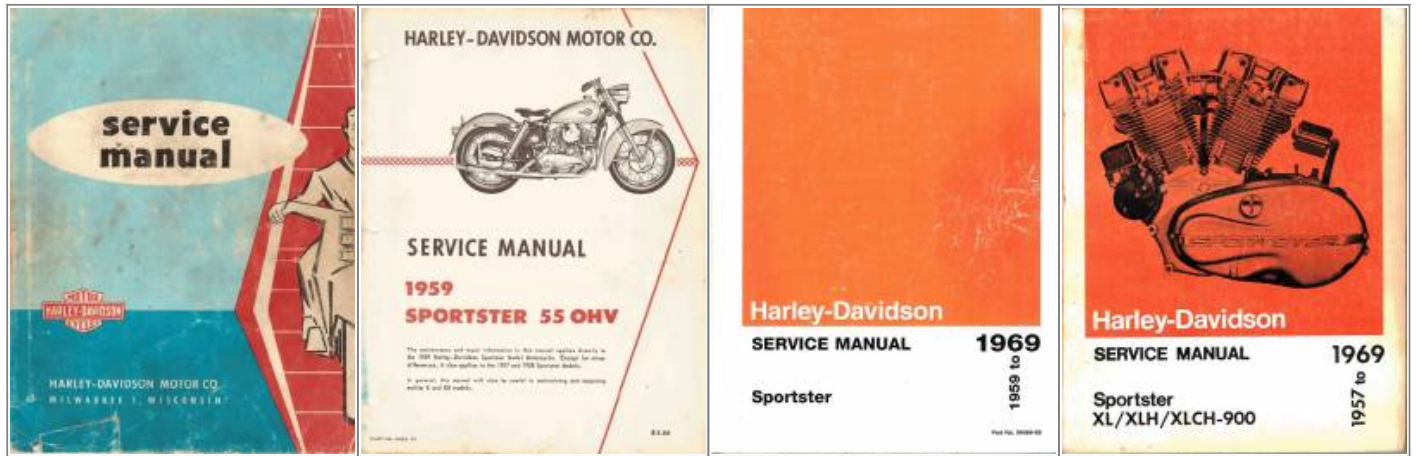

1952-1957
Parts Catalog (99451-57)

1954-1978
Parts Catalog (99451-78B)



The Ironhead Multi-Year Parts Catalog Curse

Below is a summary of an article on the Sportsterpedia Parts Catalogs page regarding parts book errors. You can also read the full article from this link: [The Ironhead Multi-Year Parts Catalog Curse](#).

Due to all of the errors and non corrected editions, it's always a good idea to acquire several year parts catalogs surrounding your year model.

Which year catalogs you'll need will depend on many factors but the main Parts Catalog page in the Sportsterpedia will help you decide which ones you need.

[Click Here](#) to see the Parts Catalog page. A full chart of all the parts catalogs made for Ironheads is at the bottom of the page.

- Not all multi-year catalogs will list factory installed parts on your bike.
- You may need several year catalogs to determine factory installed parts for your year model.
- Some parts first appeared or only appeared in Parts Supplements, Service Bulletins or other literature
- Later catalogs may show parts for older models that were never factory installed on them.
- Some catalogs have missing parts and/or missing models in some parts listings.
- Some illustrations do not have a part number listed.

- Drawings may or may not look like your part number.
- Some exploded parts diagrams show the assembly in the wrong order or missing pieces.
- There may be misleading information about parts that fit your year model.
- Fastener lengths and thread pitch may change depending on catalog used.
- The MoCo knew about and tried to correct at least some of the parts catalog mistakes.

Search the Sportsterpedia

See the Navigation menu on the upper left of this page.

From there you can go to the main Ironhead section menu, the Reference section for general and in-depth procedures, and the Misc Resources for documentation.

Illustrations

The following illustrations are displayed for historic and period specific parts identification only. Refer to the original OEM documents for additional information. ¹¹⁾

Click on any illustration below to enlarge.

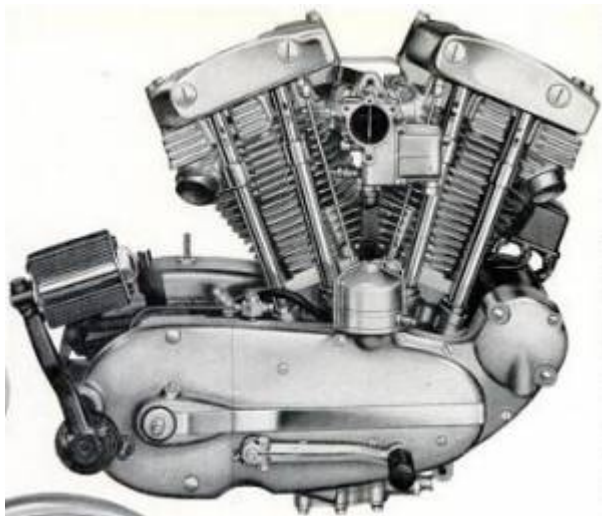

General dimension drawing for 1957-1965 XLH / XLCH frames:

This is a "short frame". Dims shown are 1957-1966 (all) and 1967-1969 XLCH. ¹²⁾

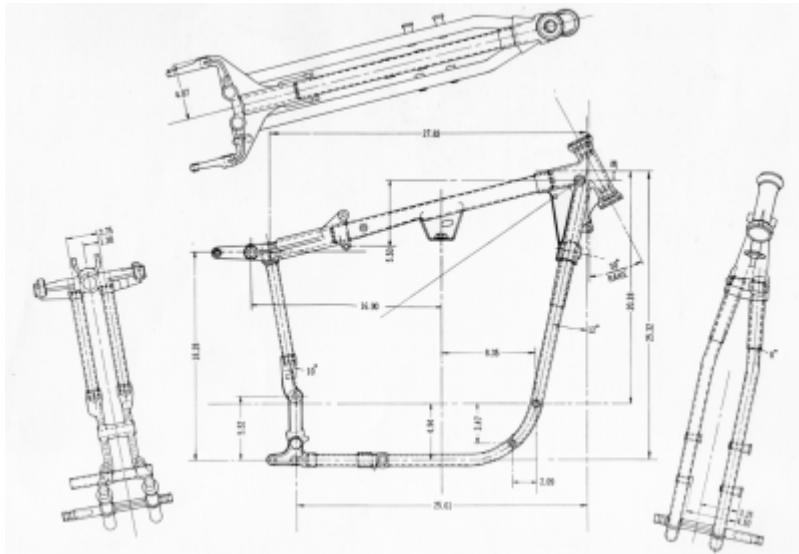

13)

Specifications

[Click Here](#) for the main technical menu in the Sportsterpedia.

Also see the "Misc Resources" section on the bottom of that page for technical docs and information.

Model Designation

- XL

Dimensions

- Wheelbase: 56.5 in / 143.51 cm ¹⁴⁾
- Overall Length: 87 in / 221 cm
- Overall Width: 34 in / 86.36 cm
- Overall Height: 40.5 in
- Saddle height 26-7/8 in to 29 in / 68.26 cm to 73.66 cm
- Road Clearance: 2.5 in to 4-5/8 in / 6.35 cm to 11.74 cm

Engine

- Engine type: 4 cycle Overhead Valves, 45 degree V2 ¹⁵⁾
- Hemi-spherical style heads
- Displacement: 53.9 ci / 883 cc (900 cc advertised)
- Compression Ratio: 7.5:1
- Bore: 3 in / 76.2 mm
- Stroke: 3.8125 in / 96.8 mm

- Horsepower: 42 @ 5,500 rpm
- Taxable Horsepower: 7.2
- Torque: 48 ft/lb @ 3.600 RPM
- Weight: 204 lbs.
- 4 Cams
- **Gear driven type oil pump.**
 - Oil pump pressure (gauge mounted in place of oil pressure switch):
 - Idle, with spark retarded (Min: 3-7 psi)
 - Normal riding conditions: 10-14 psi (6 psi at 20 mph)
- **Ignition:** Battery Ignition System (circuit breaker/points/timer/distributor)
 - Point Gap: .020"
- Dwell: 90° at 1000 RPM
- Ignition Timing
 - Advanced: 45° (11/16") BTDC
 - Retarded: 15° (5/64") BTDC
- Spark Plugs
 - #4 for everyday use.
 - #5 for hard service.
 - Gap: .025"- .030"
- **Fuel System:** Linkert DC carburetor.
- Starter: Kick start only

Capacities

- Fuel capacity: 4.1 gal / 15.52 l¹⁶⁾
- Oil Capacity: 3 qts. / 2.83 l
- Transmission Capacity: 1.5 pints / .71 l

Clutch

- Multi-Disc dry clutch-pack with alternate steel and fiber friction plates.¹⁷⁾

Drivetrain

- Constant Mesh - right side foot shift¹⁸⁾
- Speeds - 4 Forward
- Number of Sprocket Teeth
 - Engine: 34
 - Clutch: 59
 - Transmission: 21
 - Rear Wheel: 51
- Standard Gear Ratios
 - 1st: 10.63:1
 - 2nd: 7.69:1
 - 3rd: 5.82:1

- 4th: 4.21:1

Tires

Tire pressure (based on a rider weighing app. 150 lbs or more).

For each 50 lbs of overload, increase rear tire pressure by 2 lbs, front by 1 lb¹⁹⁾ but not exceeding manuf max tire pressure.

- XL:
 - Front: 3.50 x 18 (tire pressure: 14 psi / .96 bar)
 - Rear: 3.50 x 18 (tire pressure: 18 psi / 1.24 bar)

Back to [Sportster History Index](#)

1)

<http://www.hotbikeweb.com/harley-sportsters-paying-tribute-hot-rod-legend>

2) , 3) , 4) , 5) , 6) , 7)

<https://www.harleykmodel.com/technical/colors/index.html>

8)

1953-1963 HD Parts Catalog backside of front cover

9)

<http://www.harleykmodel.com/literature/spare-parts-catalogs/documents/99451-57/99451-57.pdf>

10)

pics from a collection by The French Owl of the XLFORUM

11)

illustrations from various academic journals

12)

Dr Dick of the XLFORUM <http://xlforum.net/forums/showpost.php?p=4370194&postcount=58>

13)

illustration from a collection by The French Owl of the XLFORUM

14) , 15)

Harley-Davidson 1957 - 1969 Service Manual

16)

Harley-Davidson 1960 Sportster Service Manual

17)

1957-1969 HD FSM pg 4A-3

18)

1957-1969 HD FSM pg 1A-3

19)

1959-1964 HD FSM pg 1A-3

From:

<http://sportsterpedia.com/> - **Sportsterpedia**

Permanent link:

http://sportsterpedia.com/doku.php/sportster_history:1957_sportster

Last update: **2022/01/27 04:35**

