

Table of Contents

- 1978 Sportster** 1
- Vehicle Identification** 1
 - Frame VIN Numbers** 1
 - Engine Serial Numbers** 2
- Related Manuals and Documentation** 2
 - The Ironhead Multi-Year Parts Catalog Curse** 4
 - Search the Sportsterpedia** 4
 - Illustrations** 5
- Specifications** 5
 - Model Designations 5
 - Dimensions 6
 - Engine 6
 - Capacities 7
 - Clutch 7
 - Drivetrain 7
 - Tires 7
- Models** 8
 - XLCR 1000 Cafe Racer 8
 - XLH 1000 8
 - XLH 1000 Anniversary 9
 - XLCH 1000 9

1978 Sportster

Model Production Numbers

- XLH 1000 11,271
- XLH 1000 (75th Anniversary Model) 2,323
- XLCH 1000 2,758
- XLT 1000 (Touring) 6
- XLS 1000 (Roadster) 2
- XLCR 1000
- XR-750 83 ¹⁾

Colors

- Birch White, Vivid Black, Brilliant Red, Charcoal Silver, Arctic White, Concord Blue, Chestnut Brown and Black Cherry.

Vehicle Identification

Frame VIN Numbers

Starting in 1970, the only numbers used for the purpose of identification are on the right neck and frame downtube.

- The frame is stamped with a Vehicle Identification Number (VIN) identification.
- There are still other stampings on the different parts of the frame combined with certain features that can be used to date the frame.
But the only numbers used to identify the entire bike for ownership purposes is the VIN number stamped in the right side neck.
- In addition to the neck VIN, an identification label is located on the frame giving the VIN and date of manufacture.
This label was required by law for identification.²⁾
- The serial number is the 3rd through the 7th digit. All serial numbers run consecutively regardless of model year.³⁾

[Click Here](#) to view Ironhead Frame Identification in the Sportsterpedia for more information.

[Click Here](#) for more information on serial numbers and VINs in the Sportsterpedia.

VIN for 1978 Sportsters			
Sportster Model Code (first 2 digits)	Serial Number (next 5 digits)	Manufacturer (second to last digit)	Model Year (last digit)

1C = XR-750 2G = XLT 3A = XLH 4A = XLCH 4E = XLS 7F = XLCR	10,000 and up	H = Harley Davidson	8 - 1978
Example: (3A13675H8) indicates a 1978 XLH and is stamped on the right side engine case and on the frame with the addition of a label on the steering head showing the VIN and date of manufacture. ⁴⁾			
Example VIN Reads: 3A13675H8			
3A	13675	H	8

Engine Serial Numbers

The engine serial numbers were still stamped in the case but longer used for identification purpose of ownership on 1970-up model Sportsters.

- The engine VIN is stamped on the right side of the engine crankcase between the cylinders.

Related Manuals and Documentation

Below are some suggestions for manuals for your ride.

You should have, at minimum, a Factory Service Manual (FSM) and a Factory Parts Catalog for your year model.

Factory Service Manuals (FSM);

The FSM will have the most accurate information, procedures and specs.

Clymer and Haynes make service manuals also for Sportsters but some of the information is in error to the factory FSMs.

And some of the information in the aftermarket manuals is vague in information or procedures but they may have more pictures.

So it is generally said you can get use from both an aftermarket manual and the factory service manuals but get the factory manual first.

[Click Here](#) to view the Factory Service Manual page in the Sportsterpedia.

Parts Catalogs;

The Parts Catalog has part numbers of course but it also has exploded parts views.

However, IT IS NOT INTENDED TO BE AN ASSEMBLY MANUAL.

And some of the exploded views are confusing or not related to each other on the same pages.

But, all in all, the exploded views do help finding what goes where.

Most of the fasteners listed in the relevant parts catalog individual pages have thread sizes and lengths also in case you need those.

Note: ALL 1957-1978 PARTS CATALOGS LIST PARTS FOR PREVIOUS YEARS.

Below is a simple list of original and "latest edition parts catalogs. The in-between year books may show different part numbers for the same year model bike.

[Click Here](#) to see the Factory Parts Catalog page in the Sportsterpedia for parts catalog uses and a full list of parts catalog numbers from 1957 to present.

(complete list of other parts catalogs and supplement catalogs that pertain to each year model on the bottom of that page)

Some often acquire several year model parts catalogs and that page will help you decide which ones are right for you.

Suggested Manuals:

- **Factory Service Manual (FSM):**
 - 1970-1978 Sportster XL/XLH/XLCH/XLT-1000 Service Manual (99484-78)
- **Factory Parts Catalogs:**
 - **Original:** 1954-1978 XLH/XLCH-1000 Parts Catalog Supplement (99451-78)
 - Issued October, 1977.
 - Updates the 1954-1976 full parts catalog (99451-76A).
 - Lists closest to original parts available for 1978 models.
 - **Use With:** 1954-1976 XLH/XLCH-1000 Parts Catalog (99451-76A).
Issued May, 1976. Full catalog and lists parts available in 1976 for 1954-1976 models.
 - **Updated Edition:** 1954-1978 Sportster XLH/XLCH-1000 Parts Catalog (99451-78A)
 - Issued April, 1981.
 - Full catalog and lists parts available in 1981 for 1954-1978 models.
 - **Latest Edition:** 1954-1978 Sportster XLH/XLCH-1000 Parts Catalog (99451-78B)
 - Issued in 1989.
 - Full catalog and lists parts available in 1989 for 1954-1978 models.
Includes some parts that were not available in the -78A catalog.
- **Factory Owners Manual:**
 - 1978 XL-1000/XLCH-1000 Owners Manual (99466-78)

Pics of Manual Covers.

Below are pics of used manual covers (original to latest editions) related to 1978 model Sportsters. See the full list of pertinent catalogs in the link above.

Click on any pic below to enlarge:



1954-1976 Parts Catalog (99451-76A)	1954-1978 Parts Catalog Supplement (99451-78)	1954-1978 Parts Catalog (99451-78A)	1954-1978 Parts Catalog (99451-78B)
			

The Ironhead Multi-Year Parts Catalog Curse

Below is a summary of an article on the Sportsterpedia Parts Catalogs page regarding parts book errors. You can also read the full article from this link: [The Ironhead Multi-Year Parts Catalog Curse](#).

Due to all of the errors and non corrected editions, it's always a good idea to acquire several year parts catalogs surrounding your year model.

Which year catalogs you'll need will depend on many factors but the main Parts Catalog page in the Sportsterpedia will help you decide which ones you need.

[Click Here](#) to see the Parts Catalog page. A full chart of all the parts catalogs made for Ironheads is at the bottom of the page.

- Not all multi-year catalogs will list factory installed parts on your bike.
- You may need several year catalogs to determine factory installed parts for your year model.
- Some parts first appeared or only appeared in Parts Supplements, Service Bulletins or other literature
- Later catalogs may show parts for older models that were never factory installed on them.
- Some catalogs have missing parts and/or missing models in some parts listings.
- Some illustrations do not have a part number listed.
- Drawings may or may not look like your part number.
- Some exploded parts diagrams show the assembly in the wrong order or missing pieces.
- There may be misleading information about parts that fit your year model.
- Fastener lengths and thread pitch may change depending on catalog used.
- The MoCo knew about and tried to correct at least some of the parts catalog mistakes.

Search the Sportsterpedia

See the Navigation menu on the upper left of this page.

From there you can go to the main Ironhead section menu, the Reference section for general and in-depth procedures, and the Misc Resources for documentation.

Illustrations

The following illustrations are displayed for historic and period specific parts identification only. Refer to the original OEM documents for additional information. ⁵⁾

Click on any illustration below to enlarge.

General dimension drawing for 1973-1978 XLH / XLCH frames:

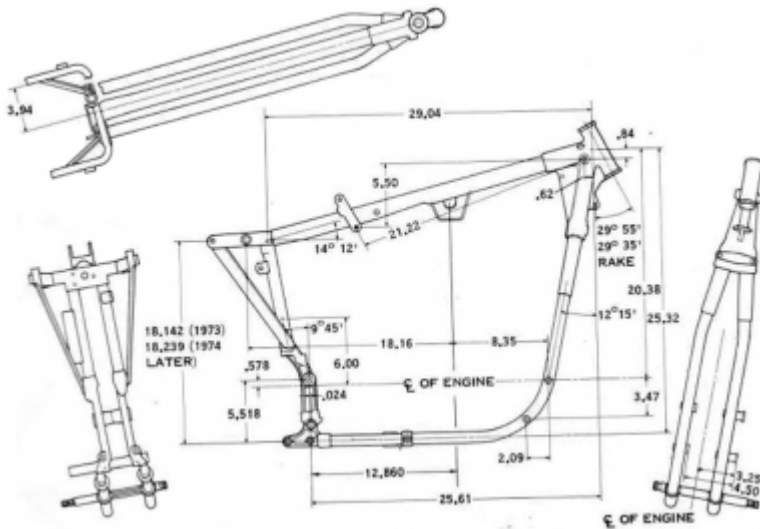

Specifications

[Click Here](#) for the main technical menu in the Sportsterpedia.

Also see the "Misc Resources" section on the bottom of that page for technical docs and information.

Model Designations

- XL, XLH, XLCH

The 57-69 service manuals and other literature from HD cover multiple years.

And the 1957-1959 "XL" is included with the information in these manuals up through 1969.

However, the 1970-1978 FSM also includes an "XL" model in the specs but does not refer to the 57-59 XL motorcycle.

Starting in 1977, there were also XLT and XLCR models (these are both included in the "XL" verbiage).

The "XL" noted in 1970 and future literature simply refers to a street legal "Sportster" model motorcycle.

The last XLCH was made in 1979 but both "XL" and "XLH" verbiage was used in manuals and literature up through the 2003 manuals.

(referring to the same bikes).

"XLH" became the mantra for the base 883cc model but the manuals also refer to XLH1100 and XLH1200 Sportsters.

2004-up manuals dropped the "H" altogether. So 2003 is the last year the MoCo referred to a Sportster

as an XLH.

Dimensions

- Wheelbase: ⁶⁾
 - XL, XLH, 58-1/2 in / 148.59 cm
 - XLCH, 58-1/2 in / 148.59 cm
- Overall Length:
 - XL, XLH, 87-3/4 in / 222.88 cm
 - XLCH, 87-3/4 in / 222.88 cm
- Overall Width:
 - XL, XLH, 35 in / 88.90 cm
 - XLCH, 35 in / 88.90 cm
- Overall Height:
 - XL, XLH, 48 in / 121.92 cm
 - XLCH, 48 in / 121.92 cm
- Road Clearance:
 - XL, XLH, 7-1/4 in / 18.41 cm ⁷⁾
 - XLCH, 7-1/4 in / 18.41 cm

Engine

- Engine type: 4 cycle Overhead Valves, 45 degree V2
- Hemi-spherical style heads
- Displacement: 60.9 ci / 997.5 cc (1,000 cc advertised)
- Compression Ratio: 9:1
- Bore: 3.188 in / 81 mm
- Stroke: 3.8125 in / 96.8 mm
- Horsepower: 59.5 @ 6,400 RPM ⁸⁾
- Taxable Horsepower: 7.2
- Torque: 52 ft-lb @ 3800 RPM
- 4 Cams
- [Gerotor type oil pump](#).
 - Oil pump pressure (gauge mounted in place of oil pressure switch):
 - Minimum: 3-7 psi (idle)
 - Maximum: 15 psi (60 mph in high gear)
 - Normal riding conditions: 4-15 psi
- [XLH/XLCH Ignition](#): Breaker Point and Coil Ignition System (points are in the nose cone in the cam cover)
 - Point Gap: .018"
- Dwell: 140° at 2000 RPM
- Ignition Timing
 - Advanced: 40° (17/32") BTDC
 - Retarded: 10° (1/32") BTDC
- Spark Plugs

- #4 for break-in.
- #5 for everyday use and hard service.
 - Gap: .025“- .030”
- **Fuel System:** Keihin (non-cv) Butterfly carburetor.
- **Starter**
 - XLCH: **Kick Start** only.
 - XLH: **Electric Start** only (Prestolite).

Capacities

- **Fuel Capacity:** ⁹⁾
 - XL / XLH fuel tank 4 gal / 15.14 l
 - XLCH fuel tank 2.2 gal / 8.328 l
 - Reserve: .25 gal / .946 l
- **Oil Capacity:** 3 qts. / 2.83 l
- **Transmission Capacity:** 1.5 pints / .71 l

Clutch

- Multi-Disc wet clutch-pack with alternate steel and fiber friction plates.¹⁰⁾

Drivetrain

- Constant Mesh ¹¹⁾
- Left Side Shifter
- Speeds - 4 Forward
- Number of Sprocket Teeth (XL / XLH / XLCH)
 - Engine: 34
 - Clutch: 59
 - Transmission: 21
 - Rear Wheel: 51
- Gear Ratios (XLH / XLCH)
 - 1st: 10.63:1
 - 2nd: 7.70:1
 - 3rd: 5.82:1
 - 4th: 4.22:1

Tires

Starting in 1970 through E1979, Harley Davidson partnered with Goodyear for a new “special” tires and rims for standard “high ground clearance” Sportster models.

Standard or Low Clearance models did not have the “special” rims and use standard tires.

[Click Here](#) for the Ironhead tires and wheels page in the Sportsterpedia for more information.

Tire pressure based on 150 lb rider. When weight is exceeded by 50 lbs or more, increase the rear by 2 lbs and front by 1 lb.

Repeat for each additional 50 lbs of weight. ¹²⁾

Tires: (both the Special Goodyear and the Yokohama tire brands are all obsolete now)

- Standard Sportster Models;
 - Front 3.25/3.50 x 19
 - Rear 4.00 x 18
- High Ground Clearance Sportster Models: ¹³⁾
 - Front;
 - Goodyear MM90-19T (3.75x19) Sport Rib (tire pressure 18 psi / 1.24 bar) ¹⁴⁾
 - Rear;
 - Goodyear 4.25x18 All Traction (tire pressure 30 psi / 2.06 bar) ¹⁵⁾
- Low Ground Clearance Models:
 - Front 3.25/3.50 x 19
 - Rear 3.50 x 18

Models

XLCR 1000 Cafe Racer

What is the Current KBB Value? ¹⁶⁾



1978 XLCR 1000 - Last year in production - click to enlarge.
(Original California model with one state only mufflers.) ¹⁷⁾

XLH 1000

What is the Current KBB Value? ¹⁸⁾

XLH 1000 Anniversary

What is the Current KBB Value? ¹⁹⁾

XLCH 1000

What is the Current KBB Value? ²⁰⁾

- Dual Sport

Back to [Sportster History Index](#)

1)

1972-2003 HD XR750 Service Manual XR 750 Production Schedule pg 69

2) 3)

HD Service School service bulletin #596 dated September 16, 1969

4)

Shop Dope Service Bulletin #596 dated September 16, 1969

5)

illustrations from various academic journals

6)

Harley-Davidson 1970 Service Manual

7)

HD 1970-1978 Sportster Service Manual

8) 9)

Harley-Davidson 1970-1978 Service Manual

10)

1957-1969 HD FSM pg 4A-3

11)

1970-1978 HD FSM pg 1-1

12)

Harley-Davidson 1970 - 1977 Service Manual

13) 14) 15)

Harley-Davidson 1970 Service Manual pg 1-1

16)

<http://www.kbb.com/motorcycles/harley-davidson/xlcr-cafe-racer/1978-harley-davidson-xlcr-cafe-racer/trade-in/>

17)

Photo courtesy of Moon Wolf of the XLFORUM

18)

<http://www.kbb.com/motorcycles/harley-davidson/xlh-sportster-1000/1978-harley-davidson-xlh-sportster-1000/trade-in/>

19)

<http://www.kbb.com/motorcycles/harley-davidson/xlh-sportster-1000-anniversary/1978-harley-davidson-xlh-sportster-1000-anniversary/trade-in/>

20)

<http://www.kbb.com/motorcycles/harley-davidson/xlch-sportster-1000/1978-harley-davidson-xlch-sportster-1000/trade-in/>

From:

<https://sportsterpedia.com/> - **Sportsterpedia**

Permanent link:

https://sportsterpedia.com/doku.php/sportster_history:1978_sportster

Last update: **2024/01/25 18:05**

