

Buell[®]
AMERICAN MOTORCYCLES

BUELL
BYTES

COMPUTER GENERATED
TECHNICAL UPDATES & INFORMATION
FOR BUELL MOTORCYCLES

ISSUE #3

NOVEMBER 1995

TABLE OF CONTENTS

<u>PAGE</u>	<u>TOPIC</u>
1-4	Lightning Strikes !!!
5	S1 Electrical Wiring Diagram
6	New S2/S2-T Parts

A stylized graphic featuring the text 'S1-Lightning' in a large, bold, black font. The 'S1' is significantly larger than the rest of the text. Below 'S1-Lightning', the word 'STRIKES' is written in a smaller, black, serif font, followed by two exclamation points '!!'. The background of the graphic is white, and there are some black, jagged, lightning-bolt-like shapes around the text.

This special issue of *Buell Bytes* is dedicated to the exciting new S1-Lightning! Units are being crated and will be shipped for arrival at your dealership soon. It is **very important** that you become familiar with the information in the S1-Lightning's Predelivery & Set-up Manual, part number 99946-96Y. Some of the vehicle features will introduce the technician to new service procedures and technology.

We are highlighting the S1's new features in this issue as an introduction to the extensive changes of this new motorcycle!!

S1-LIGHTNING TECHNICAL HIGHLIGHTS



LOW MAINTENANCE BATTERY

- The S1-Lightning's "Genesis" battery is a totally sealed battery which requires very little predelivery/setup, maintenance, or servicing.
- The battery will arrive fully charged.
- No addition of electrolyte or distilled water will be necessary.
- No need to plan any set-up time for battery activation.
- There is no vent hose to route.
- This battery features an extremely slow discharge rate. So in most climates and conditions, except maybe Santa's, this means no periodic charging during winter storage. Just leave the battery in the vehicle or on the shelf and it will start the motorcycle in spring!!
- A simple voltage check will verify the state of charge and if there is need for any charging. You won't harm this battery by charging with higher amperage chargers than you're used to using on lead acid batteries. It will merely reduce the recharging time needed!!

- If you do remove or install a battery cable, say the negative lead to service the transmission, make sure that you **HOLD THE CABLE** to keep the battery cable from twisting. The torque spec. is only **30-40 in./lbs.**, but any rotational forces or higher torques could cause damage to the studs or backing nuts.

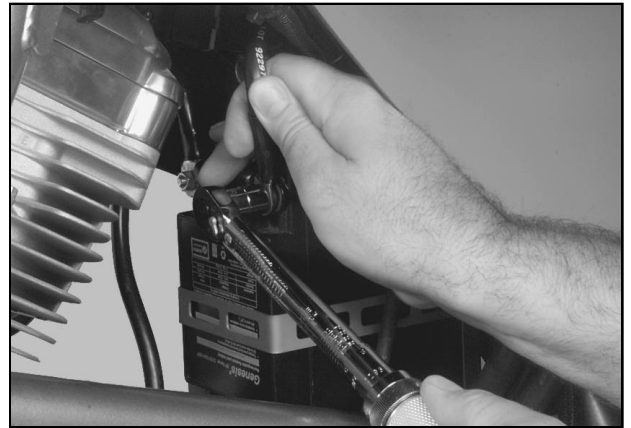

TIRE PRESSURES

- The S1-Lightning upgrades to the next generation of sportbike tires: the Dunlop Sportmax Radial II.
- Dunlop and Buell are recommending **one tire pressure** for each tire, irregardless of the load. Solo or two-up the tire pressure should be set to 32 psi for the front and 36 psi for the rear tire.

IGNITION TIMING

- Ignition timing is checked with the vehicle idling between **950 - 1050 rpm**. The timing mark will now be a pair of side by side drilled dots or "lazy 8".

OILING SYSTEM

- The oil tank is located under the seat, which you will remove to access the dipstick. That's OK because tools aren't needed to do that. Oil capacity is two quarts. The difference between the upper and lower dipstick marks is 1/2 quart.
- The oil tank drain hose plug is secured to a frame retaining loop. Compress the clamp to pull the hose free of the plug. Then direct it into a drain container.

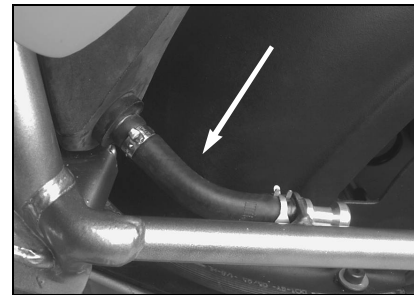

ELECTRICAL FUSES

- The individual electrical circuits are protected by four 15 Amp replaceable fuses. They're located on a fuseblock which is secured to a frame bracket. The fuses are cosmetically hidden under the edge of the painted rear tailsection. Fuses can be replaced without using any tools or removal of the seat and tailsection.
- The main breaker is a 30 Amp circuit breaker.

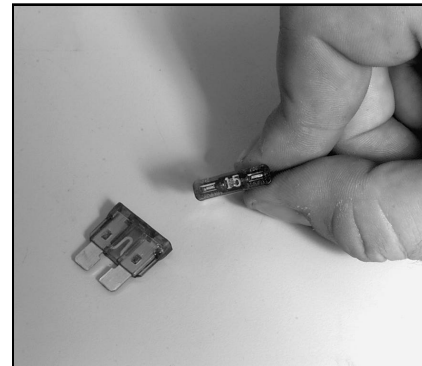

HEADLIGHT ADJUSTMENT

- The headlight adjustments (vertical & horizontal) are easily made using two **Metric** adjusters which also hold the headlight assembly to the fork brackets. The H4 headlight is adjusted with the **HIGH BEAM** on.
- Remember, the rectangular sealed bulb assembly of the S2 makes the adjustment using the **LOW BEAM** filament.

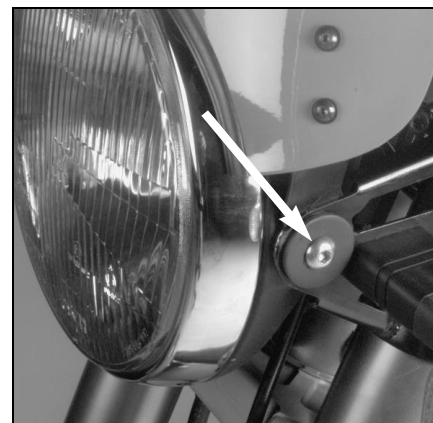

STARTER INTERLOCK

- The S1-Lightning is equipped with an interlock system that will turn off the engine if forward motion takes place, in gear, with the side stand in the extended position.
- The system will also prevent starting, in gear, unless the clutch lever is disengaged or the vehicle is in neutral.
- Complete servicing information will be included in the Predelivery and Service Manuals.
- Your customer should be completely familiar with the system's features as part of the vehicle's delivery.

BELT DEFLECTION

- The adjustment procedure is the same. The recommended belt deflection is $7/8 - 1"$.

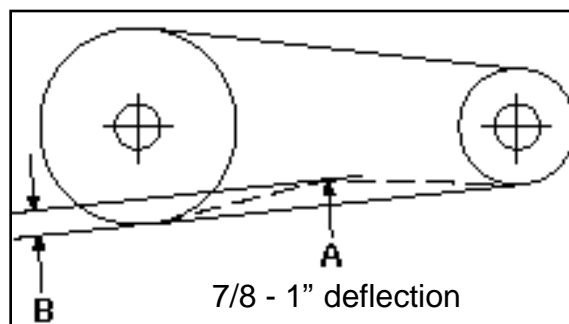

SUSPENSION ADJUSTMENTS

- The WP Roma 4054 front suspension compression adjusters have been removed from the lower fork legs. Both rebound and compression adjustments are now located on the fork caps. One adjuster is for compression damping and the other controls the rebound damping.
- The rear WP Roma 4861 Pull Shock has been tuned for the lighter weight and horsepower of the S1. Check the Predelivery & Setup Manual for the new recommended settings for preload, compression and rebound adjustments.

SERVICE LITERATURE

1996 S1-LIGHTNING

Predelivery & Setup Manual	99946-96Y
Warranty Job/Time Code	99996-96Y
Service Manual	99490-96Y
Parts Catalog	99571-96Y

1996 S2-THUNDERBOLT

Predelivery & Setup Manual	99947-96Y
Warranty Job/Time Code	99997-96Y
Service Manual	99489-96Y
Parts Catalog	99570-96Y

b0245x7x

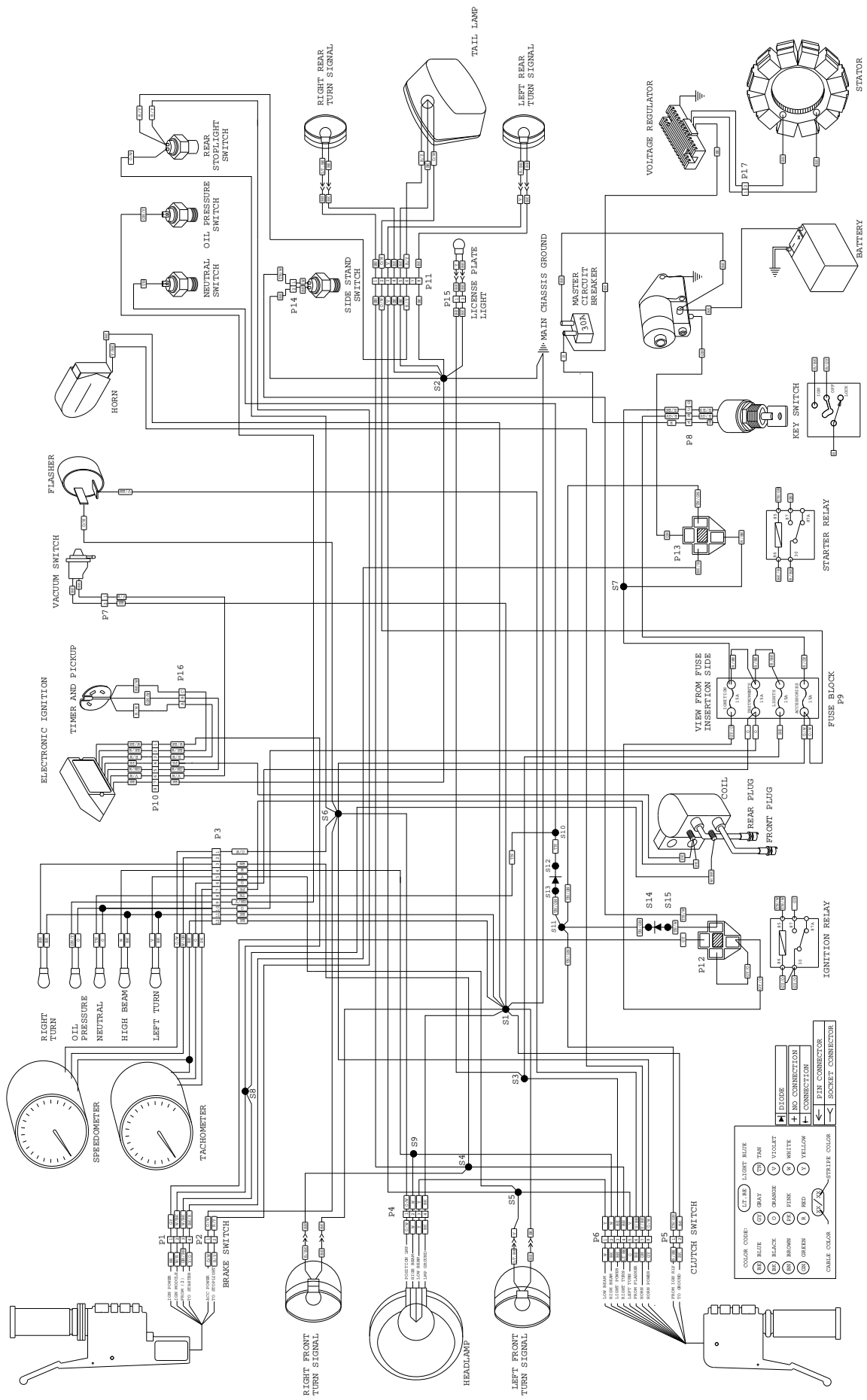

NEW S2/S2-T PARTS

Mirror Spacers

Production Thunderbolt vehicles now have one small spacer on each mirror fastener. This provides additional support through the fiberglass fairing. The change began with the following vehicle VIN numbers:

1996	49 state	Calif.
S2	166	001
S2-T	069	001

Seat Changes

A new plastic seat base, a second seat bracket and frame bracket are just some of the recent additions to both S2 & S2-T model seats.

A revised locking tang engages a new slot in the seat base.

1996	49 state	Calif.
S2	074	001
S2-T	172	001

